



**Advantages**

- Radial misalignment of 2 mm is possible
- No coupling stroke required
- No protruding contours
- Compact dimensions

**Coupling situation**

**Closed**

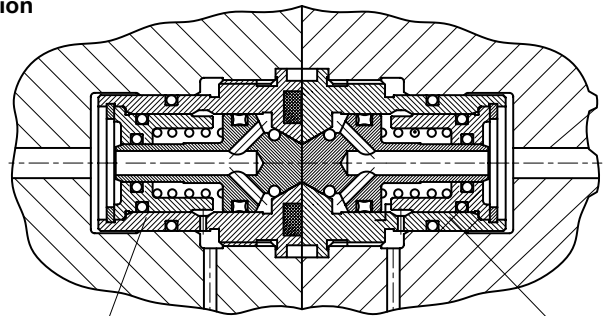

**Opened**

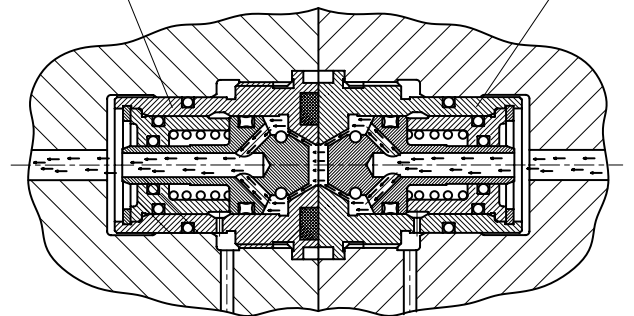

Fixture

Pressure generator side

**Application**

Coupling elements are used on machine tools with pallet changing systems in order to transmit hydraulic oil and compressed air from the machine tool table to the fixture.

**Description**

These automatically closing couplings have a flat surface and do not have protruding elements for sealing. Therefore exact positioning is not required and a radial positioning misalignment of up to 2 mm is admitted.

Cleaning of the coupling surfaces is easily possible due to the flat surfaces.

Because of the omitted active axial coupling stroke completely new solutions for the coupling motion can be realised .

**Function**

These patented couplings do not open their check valves as usual by mutual pushing open via the coupling stroke but due to the pressure increase in the hydraulic line.

The internal check valves (coupling ram) of both coupling elements are designed as pistons.

In depressurised mode they are maintained closed by a pressure spring. As soon as a pressure is built up in the line, which is higher than the force of the pressure spring, coupling (1) at the pressure generator side will be opened. Now the pressure is also available at the front face of the opposite coupling (2) and opens this coupling correspondingly. The line has free passage to the connected cylinder.

If the line will be relieved from pressure, the couplings close automatically as soon as the pressure drops below the closing pressure.

**Coupling versions**

**Version „S“**

This coupling is equipped with a standard pressure spring. Therefore this version is particularly suitable for double-acting hydraulic cylinders (see minimum opening pressure and closing pressure).

**Version „L“**

This coupling is equipped with a pressure-reduced pressure spring. Thereby the minimum opening pressure and the closing pressure are reduced. This version is particularly suitable for single-acting cylinders as well as for pneumatic applications with some restrictions (pay attention to the minimum opening pressure and closing pressure).

**Application example**

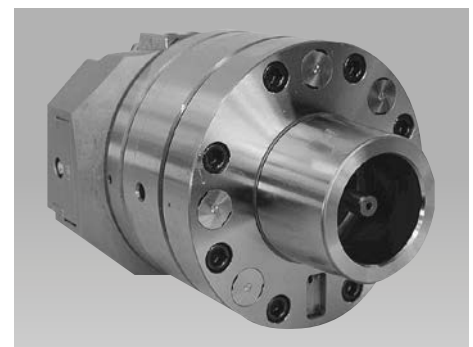

Changing fixture with 6 couplings for the machining of turbine blades.

# Technical Data Dimensions

## Technical data

		Version „S“ (standard spring)	Version „L“ (reduced spring force)
Max. flow rate	[l/min]	8	8
Minimum opening pressure coupled	[bar]	7	5
uncoupled	[bar]	6	5
Closing pressure at the consumer side coupled*	[bar]	3	2
Max. operating pressure	[bar]	200	200
Nominal diameter	[mm]	4	4
Max. positioning tolerance, radial	[mm]	2	2
Max. positioning tolerance, axial	[mm]	+0.05	+0.05

## Part no.

with sealing ring at the front face	<b>0461021</b>	<b>0461011</b>
without sealing ring at the front face	<b>0461022</b>	<b>0461012</b>

## Accessory

Screw-in tool	<b>2010906</b>	<b>2010906</b>
Sealing ring (Spare part)	<b>3001831</b>	<b>3001831</b>

\* The return pressure of a connected single-acting cylinder must be higher than the table value.

## Axial coupling force

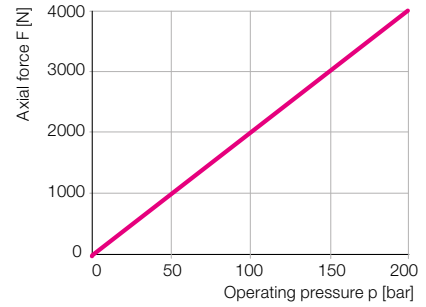

## Characteristic curve

for cinematic viscosity 53 mm<sup>2</sup>/s  
(HLP 22 at 20 °C)

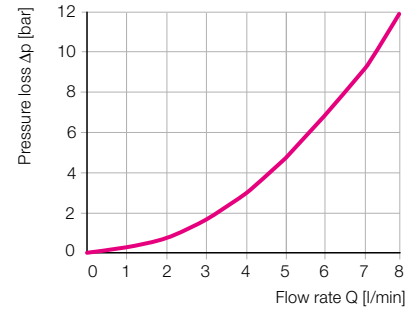

## Location hole

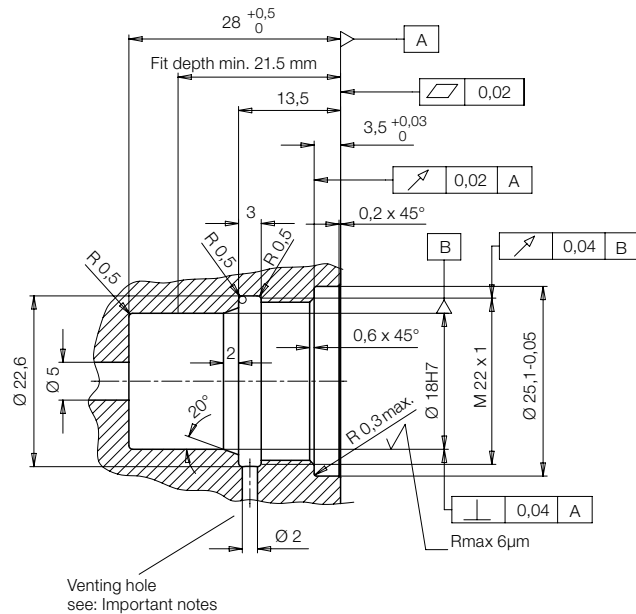

## Coupling element with sealing ring at the front face

Material: case-hardening steel, hardened

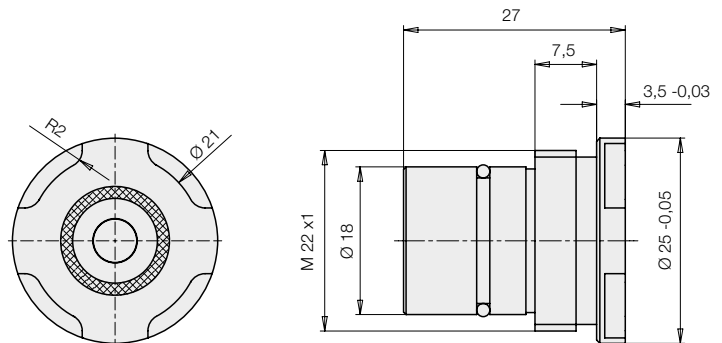

## Important notes!

- The axial forces generated in the coupling situation have to be compensated externally by force fit or form fit.
- During the coupling process the flat faces of the coupling elements must always contact each other, axial clearance is not admitted.
- The sealing surfaces on the face of the coupling elements have to be cleaned before coupling to ensure the tightness in coupled condition. We recommend to wash the elements and to clean them with compressed air. Protection covers should be used as far as possible.
- The coupling with the sealing at the front face should be mounted into the interchangeable part (e.g. pallet or changing fixture) and the coupling with the flat front face into the stationary component, since this version is more appropriate for manual or automatic cleaning.
- In uncoupled mode, the pressure in the line must be always lower than the minimum opening pressure to make sure that the couplings remain closed.
- The venting hole for the spring area is important for a perfect functioning of the coupling. No liquids and swarf must enter from the exterior.