

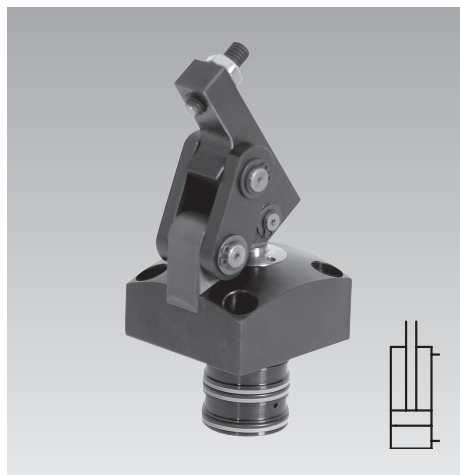

Hinge clamp

with metallic wiper edge and optional position monitoring,
double acting, max. operating pressure 250 bar



Advantages

- Compact design, partially recessible
- Clamping possible without side loads
- Standard metallic wiper edge
- FKM seals as standard

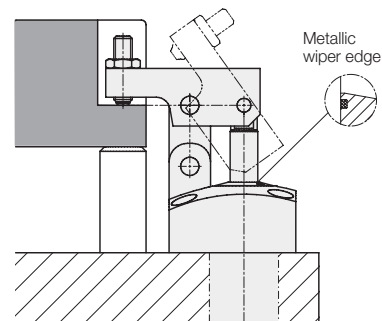

Special features

- Lever mechanism easy to clean
- Inductive or pneumatic monitoring possible

Materials

Body: C 45 + C black oxide
Seals: FKM
Clamping lever: C 45 + C
Piston: High alloy steel

Function

The piston force is deviated via sophisticated kinematics by 180° and is available as clamping force with virtually no loss of efficiency. If the level of the clamping surface is exactly at height h (see page 2), no side loads are channelled into the workpiece.

Versions

- 4 sizes

Accessories

- Intermediate plates
- Long clamping lever
- Add-on parts for inductive or pneumatic monitoring on request

Installation and connecting possibilities

Cartridge type

For horizontally-drilled channels

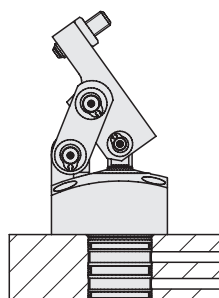

Pipe thread

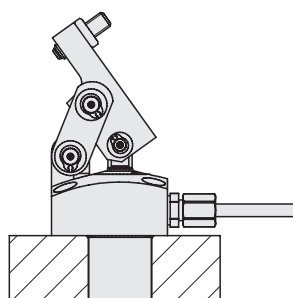

For vertically-drilled channels

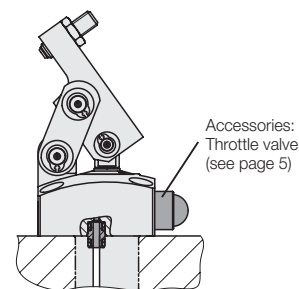

Oil supply by plug-type connectors

With extended piston rod

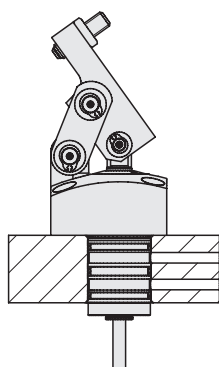

Possible from 3 sides

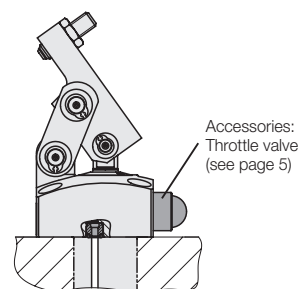
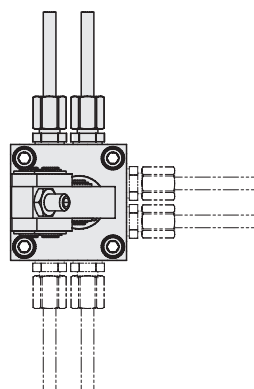

Oil supply by bushing for manifold connection
(for precision-machined support surface)

Operating conditions, tolerances and other data see data sheet A 0.100.

Code for part numbers Accessories • Technical data

Code for part numbers

- 1 = Size 1
- 2 = Size 2
- 3 = Size 3
- 4 = Size 4

- 1 = Cartridge type
- 2 = Cartridge type with extended piston rod \diamond
- 3 = Pipe thread at the back / plug-type connector
- 4 = Pipe thread at the back / plug-type connector with extended piston rod \diamond
- 5 = Pipe thread on three sides
- 6 = Pipe thread on three sides with extended piston rod \diamond

\diamond Condition for mounted position monitoring (addition: E or P)

1825 X X X (X)
Basic type

- E = mounted position monitoring, inductive (without proximity switch)
- P = mounted position monitoring, pneumatic

- 0 = without clamping lever
- 1 = clamping levers with swivel contact bolt
- 2 = long clamping lever, unmachined
Material: C45 + C (1.0503)

Cartridge type

Examples

Location hole

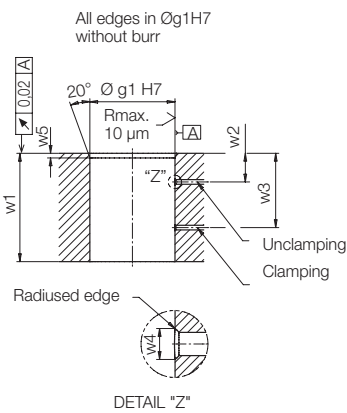

Clamping lever with swivel contact bolt

Without clamping lever and extended piston rod

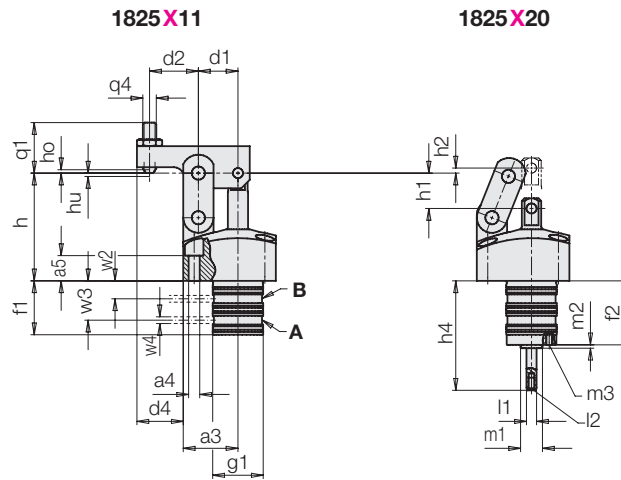

A = Clamping
B = Unclamping

Optional on request

With pneumatic position monitoring

with inductive position monitoring / long clamping lever

Long clamping lever available for all versions

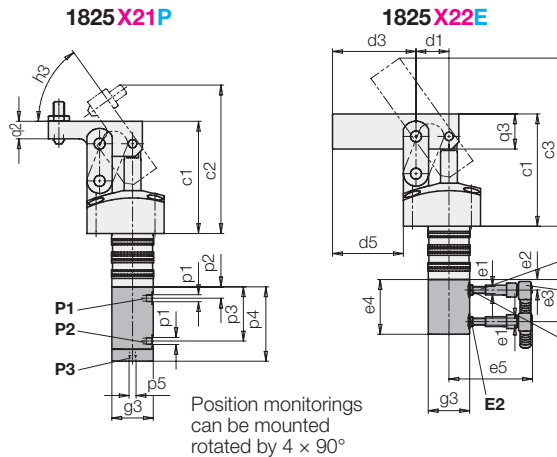

- E1 = Clamping range, inductive
- E2 = Unclamped, inductive
- P1 = Clamping range, pneumatic
- P2 = Unclamped, pneumatic
- P3 = Outlet air, pneumatic position monitoring

Accessories:
Inductive proximity switch
Plug and cable
E1

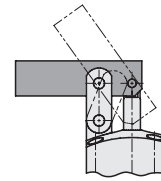

Alternatively all versions are also available without clamping lever.

Position monitorings can be mounted rotated by 4 x 90°

Accessories for size

	1	2	3	4
Pneumatic position monitoring, complete *)	0353 845	0353 853	0353 855	0353 962
Weight [kg]	0.18	0.42	0.46	0.74
Inductive position monitoring, (without inductive proximity switches) *)	0353 846	0353 854	0353 856	0353 963
Weight [kg]	0.26	0.62	0.65	0.58
Inductive proximity switch	3829 198	3829 198	3829 198	3829 198
Right angle plug with cable 5 m for inductive proximity switch	3829 099	3829 099	3829 099	3829 099

On request

*) Mountable only for versions with extended piston rod (1825 X2X, -X4X, -X6X)

Operating conditions, tolerances and other data see data sheet A 0.100.

Technical characteristics for inductive proximity switches 3829 198

Operating voltage UB	10 ... 30 V DC
Switching function	Interlock
Output	PNP
Housing material	Steel, corrosion resistant
Protection as per DIN 40050	IP 67
Ambient temperature	-25 ... +70 °C
Type of connection	Plug S49 M8 x 1
LED function display	Yes
Constant current max.	100 mA
Rated operating distance	0.8 mm
Protected against short circuits	Yes

Code for part numbers Accessories • Technical data

Code for part numbers

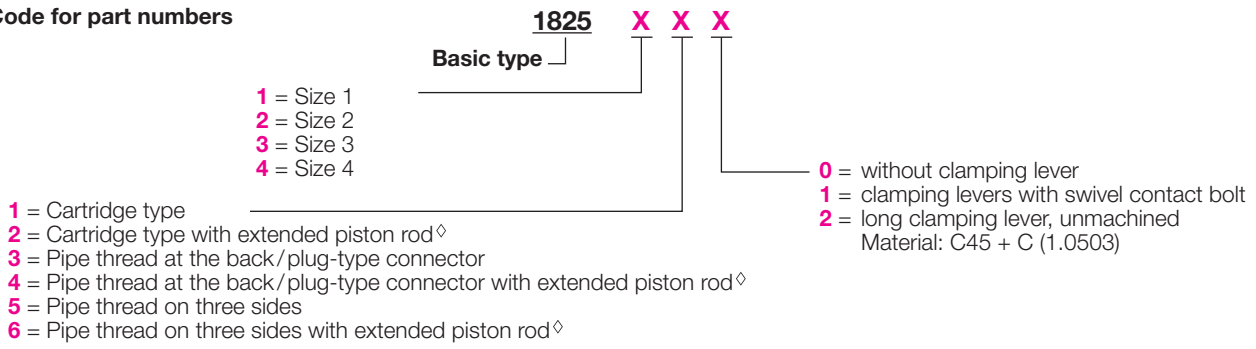

Pipe thread at the rear / plug-type connector

Clamping lever with swivel contact bolt

1825 X31

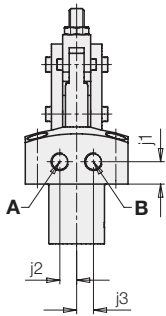

Without clamping lever extended piston rod

1825 X40

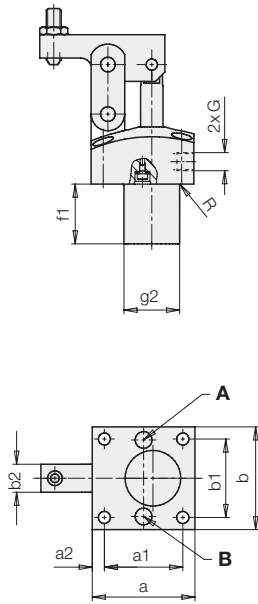

Pipe thread on three sides

Clamping lever with swivel contact bolt

1825 X51

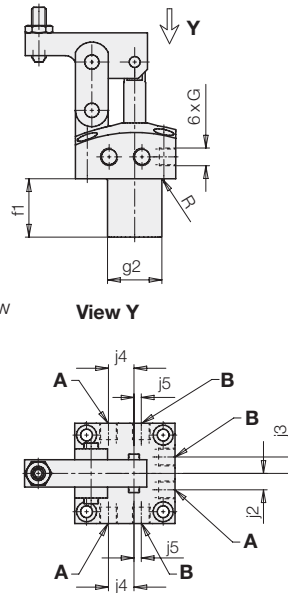

Without clamping lever extended piston rod

1825 X60

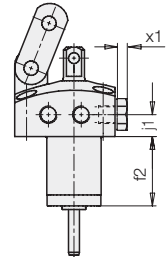

Socket head cap screw with USIT ring

4 x screw plug with sealing edge included in the delivery (dimension x1)

A = Clamping
B = Unclamping

Accessories for size

	1	2	3	4
Plugs, flush screwable with hexagon socket	0361986	0361986	0361987	0361987
Screw plug with hexagon head	3610047	3610047	3300821	3300821

Accessories

Intermediate plates

for all versions with pipe thread

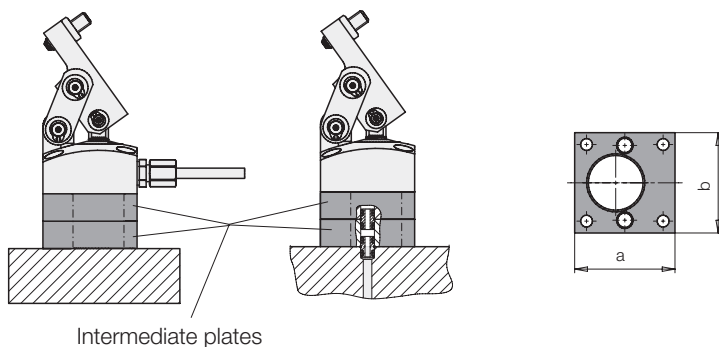

Intermediate plates

Accessories for size

	1	2	3	4
Intermediate plate (not for cartridge-type version)	3456449	3456468	3456489	3456534

Operating conditions, tolerances and other data see data sheet A 0.100.

Accessories Technical data

Plug-type connector

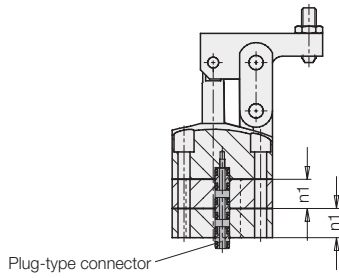

Bushing for manifold connection

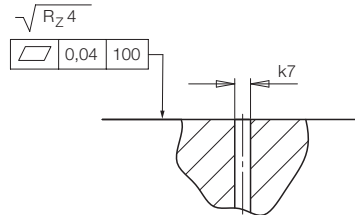
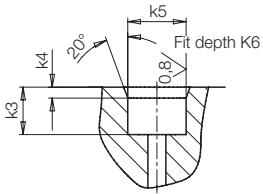
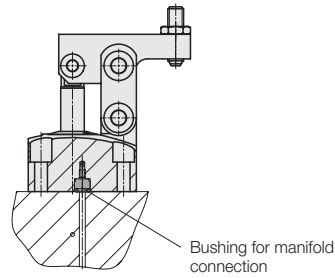

For oil supply through plug-type connectors, these bore holes have to be provided in the base plate.
 Required accessory when using plug-type connectors:
 2 x sealing plug or 2 x screw plug (see page 3)

Accessories for size	1	2	3	4
Plug-type connector	9210 145	9210 145	9210 145	9210 132
Bushing for manifold connection	9210 166	9210 166	9210 166	9210 167

Connecting dimensions for self-manufactured clamping levers

Size	1	2	3	4
d1 [mm]	23.5	33	37	43.5
q3 [mm]	25	40	50	55
s1 [mm]	7	10.5	13	16.5
s2 [mm]	Ø8 H7	Ø12 H7	Ø15 H7	Ø18 H7
s3 [mm]	Ø6 H7	Ø9 H7	Ø12 H7	Ø14 H7
t1 [mm]	15 -0.1	20 -0.1	25 -0.1	30 -0.1
t2 [mm]	9	16.5	20	20
t3 [mm]	5	8	12	12
t4 [mm]	5	8	32	32
u1 [mm]	18	27.5	35.5	40
u2 [mm]	18	24	31	40
u3 [mm]	8.1 +0.1	10 +0.1	13 +0.1	18 +0.2

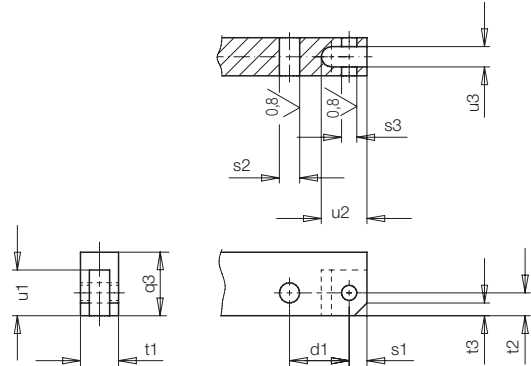

Operating conditions, tolerances and other data see data sheet A 0.100.

Accessories Technical data

Accessory throttle valve

Throttle valves are used

- in order to reduce the actuation speed of the clamping arm
- in order to improve the synchronism of several hinge clamps

This application is only possible for connection through vertically drilled channels.

Important note

If throttling is too strong, the back pressure can trigger premature switching of pressure switches and sequence valves.

Hinge clamp

Size		1+2	3+4
A	[mm]	16	21
B max.	[mm]	13.5	17.5
C	[mm]	18	23.6
G		G 1/8	G 1/4
SW1	[mm]	14	19
Tightening torque	[Nm]	18	35
SW2	[mm]	8	8
SW3	[mm]	2.5	2.5
Weight	[kg]	0.025	0.036
Part no.		2957 209	2957 210

Hydraulic symbol

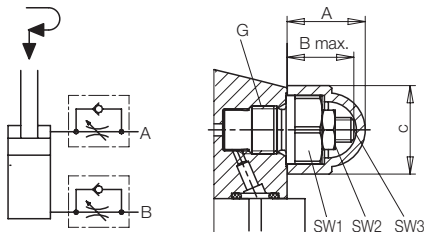

Sealing for holder

If a seal for the holder/basic fixture is necessary, we recommend use of an O-ring.

Note

Any reworking of the hinge clamp is not permitted!

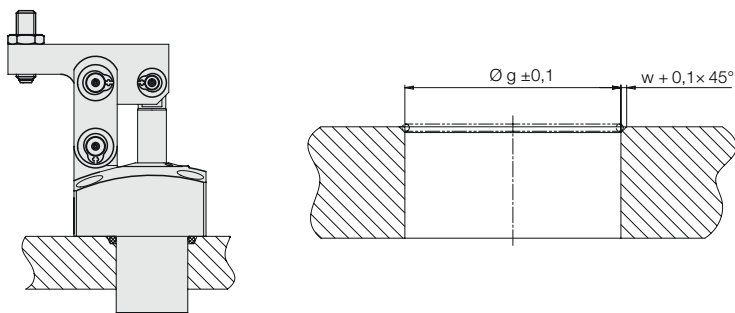

Size	1	2	3	4
Bore hole $g \pm 0.1$	30	42	52	65
Chamfer $w + 0.1 \times 45^\circ$	2.4	2.4	2.4	2.4
Recommendation O-ring	28.3 × 1.78	41 × 1.78	50.52 × 1.78	63.22 × 1.78

Technical data Dimensions

Size			1	2	3	4
Clamping force at clamping lever length d2 and 250 bar	[kN]		3.8	9.7	14.4	21.5
Clamping force at clamping lever length d2 and 250 bar	[kN]		3.3	9.1	13.9	21
Oil volume, clamping	[cm ³]		4.8	16.9	31.1	61.6
Oil volume, clamping	[cm ³]		4.1	16.0	30.0	60.2
Oil volume, unclamping	[cm ³]		2.1	10.0	19.0	37.5
Admissible flow rate	[cm ³ /s]		15.7	24.5	24.5	55
a	[mm]		55	70	85	100
a1	[mm]		42	56	69	81
a2	[mm]		6.5	7	8	9.5
a3	[mm]		32.5	46	52	60
a4	[mm]		4 × Ø 6.6	4 × Ø 9	4 × Ø 11	4 × Ø 13.5
a5	[mm]		15	18	21.5	30
b	[mm]		55	70	85	100
b1	[mm]		42	56	69	81
b2	[mm]		15	20	25	30
c1	[mm]		80	116	143	163
c2	[mm]		106	150	185	208
c3	[mm]		120	171	208	238.8
d1	[mm]		23.5	33	37	43.5
d2	[mm]		29	39.5	49	60.5
d3	[mm]		59.5	81.5	98	114
d4	[mm]		27.5	37.5	47.5	57.5
d5	[mm]		50.5	68.5	83	97.5
e1			M5×0.5	M5×0.5	M5×0.5	M5×0.5
e2	[mm]		7.5	9.7	11.6	14.5
e3	[mm]		30	41.9	46	58.3
e4	[mm]		39	49	55	68.5
e5	[mm]		approx. 60	approx. 60	approx. 60	approx. 60
f1	[mm]		32	43	44.5	52.5
f2	[mm]		38	49	50.5	58.5
G			G1/8	G1/8	G1/4	G1/4
Max. size of connecting fitting			6 L	8 S	10 L	10L
g1	[mm]		Ø 30 f7	Ø 42 f7	Ø 52 f7	Ø 65 f7
g2	[mm]		Ø 29.8	Ø 41.8	Ø 51.8	Ø 64.8
g3	[mm]		Ø 29.5	Ø 39	Ø 39	Ø 39
h ideal clamping point	[mm]		64	92.5	113	128
ho upper end of the clamping range	[mm]		2	2.7	3.5	4.5
hu lower end of the clamping range	[mm]		2	2.7	3.5	4.5
h1 piston stroke up to ideal clamping point	[mm]		21	30	33.5	41.5
h2 piston stroke up to the end of the clamping stroke	[mm]		3	4.5	5.2	7.5
h3	[°]		54.5	55.5	56	58.2
h4	[mm]		65	86.5	93	111
j1	[mm]		12	16	17	20
j2	[mm]		9	13.5	15.5	22
j3	[mm]		9	13.5	15.5	22
j4	[mm]		14	20	25	32
j5	[mm]		4	2	6	12
k1	[mm]		41 ± 0.02	55 ± 0.02	68 ± 0.02	80 ± 0.02
k2	[mm]		5 ± 0.05	0 ± 0.05	0 ± 0.05	0 ± 0.05
k3	[mm]		6.5	6.5	6.5	8
k4	[mm]		1.5	1.5	1.5	1.5
k5	[mm]		Ø 8 H7	Ø 8 H7	Ø 8 H7	Ø 10 H7
k6	[mm]		5.5	5.5	5.5	7
k7	[mm]		3	3	3	4
l1	[mm]		Ø 6 f7	Ø 6 f7	Ø 6 f7	Ø 6 f7
l2			M4×7.5 deep	M4×7.5 deep	M4×7.5 deep	M4×7.5 deep
m1	[mm]		Ø 13 f7	Ø 13 f7	Ø 13 f7	Ø 13 f7
m2	[mm]		2	2	2	2
m3			M4×6 deep	M4×6 deep	M4×6 deep	M4×6 deep
m4	[mm]		21	27	27	27
n1	[mm]		16	21.5	22.5	26.5
p1			M5	M5	M5	M5
p2	[mm]		8.5	10.6	12.3	15.2
p3	[mm]		38.6	50.9	55.1	66.5
p4	[mm]		53	73	77	84
p5			M5	G1/4	G1/4	G1/4
q1	[mm]		30	40	50	50
q2	[mm]		12.5	20	25	28
q3	[mm]		25	40	50	55
q4			M8	M12	M16	M16
R	[mm]		0.3	0.3	0.3	0.3
w1	[mm]		min. 31.5	min. 41.5	min. 43.5	51.5
w2	[mm]		10.6	14.3	14.8	18
w3	[mm]		23.4	30.7	31.9	37.5
w4	[mm]		max. Ø 4	max. Ø 5.5	max. Ø 5.5	max. Ø 5.5
w5	[mm]		2.5 – 0.5	2.5 – 0.5	2.5 – 0.5	2.5 – 0.5
x1	[mm]		7	7	8	8
Weight approx.	[kg]	1825 XX0	1.0	2.3	3.8	6.1
	[kg]	1825 XX1	1.1	2.7	4.6	7.3
	[kg]	1825 XX2	1.2	3.0	5.1	8.1

Calculations • Clamping force diagrams

Code for part numbers • Accessories

Calculations

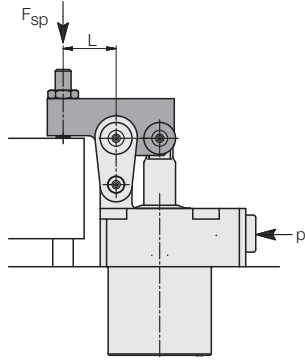

1. Length L of clamping lever is known

1.1 Admissible operating pressure

$$p_{adm} = \frac{B}{\frac{C}{L} + 1} \leq 250 \text{ bar} \quad [\text{bar}]$$

1.2 Effective clamping force

$$p_{adm} > 250 \text{ bar} \rightarrow F_{sp} = \frac{A}{L} * 250 \text{ [kN]}$$

$$p_{adm} < 250 \text{ bar} \rightarrow F_{sp} = \frac{A}{L} * p_{adm} \text{ [kN]}$$

2. Min. clamping lever length

$$L_{min.} = \frac{C}{\frac{B}{p} - 1} \text{ [mm]}$$

L, L_{min} = length of clamping lever [mm]

p, p_{adm} = operating pressure [bar]

A, B, C, = constants as per chart

Constant

	18251	18252	18253	18254
A	0.449	1.54	2.827	5.193
A*	0.386	1.45	2.728	5.076
B	442.45	448.42	429.34	429.75
B*	514.86	475.83	444.98	420.08
C	22.325	31.35	35.15	43.5

A*, B* for version with switch rod

Example 1: Hinge clamp 1825 111

Operating pressure 200 bar

Standard clamping lever L = 29 mm

Effective clamping force

$$F_{Sp} = \frac{A}{L} * p = \frac{0.449}{29} * 200 = 3.1 \text{ kN}$$

Example 2: Hinge clamp 1825 110

Operating pressure 200 bar

Min. clamping lever length

$$L_{min} = \frac{C}{\frac{B}{p} - 1} = \frac{22.325}{\frac{442.45}{200} - 1} = 18.4 \text{ mm}$$

Effective clamping force

$$F_{Sp} = \frac{A}{L} * p = \frac{0.449}{18.4} * 200 = 4.9 \text{ kN}$$

Example 3: Hinge clamp 1825210

Special clamping lever L = 30 mm

Admissible operating pressure

$$p_{adm} = \frac{B}{\frac{C}{L} + 1} = \frac{448.42}{\frac{31.35}{30} + 1} = 219 \text{ bar}$$

Effective clamping force

$$F_{Sp} = \frac{A}{L} * p_{adm} = \frac{1.54}{30} * 219 = 11.25 \text{ kN}$$

Example 4: Hinge clamp 1825310

Special clamping lever L = 118 mm

Admissible operating pressure

$$p_{adm} = \frac{B}{\frac{C}{L} + 1} = \frac{429.34}{\frac{35.15}{118} + 1} = 330.8 > 250 \text{ bar}$$

Effective clamping force

The max. operating pressure is 250 bar, thus

$$F_{Sp} = \frac{A}{L} * 250 = \frac{2.827}{118} * 250 = 6 \text{ kN}$$

Important note

Longer special clamping levers have a greater weight. Therefore the flow rate has to be considerably reduced to avoid damage of the mechanics in the stroke end positions.

A flow rate throttling always has to be effected in the supply line to the hinge clamp.

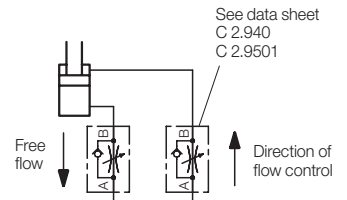

Clamping force diagrams

Size 1

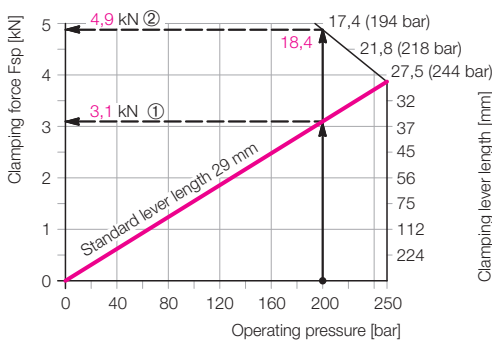

Size 2

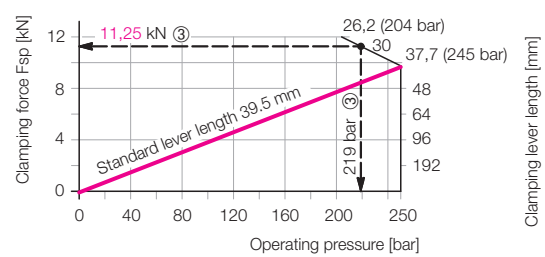

Size 3

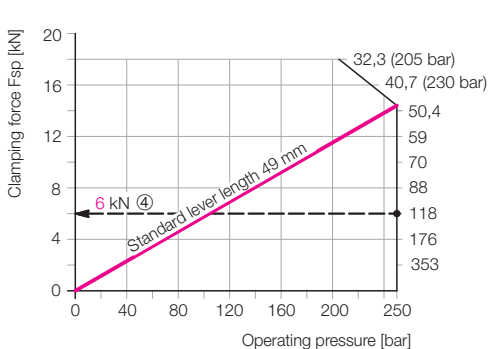

Size 4

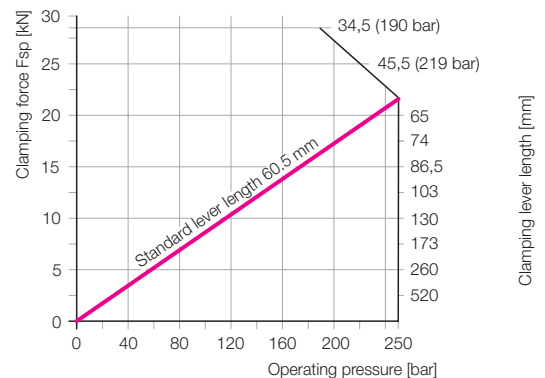

Operating conditions, tolerances and other data see data sheet A 0.100.