

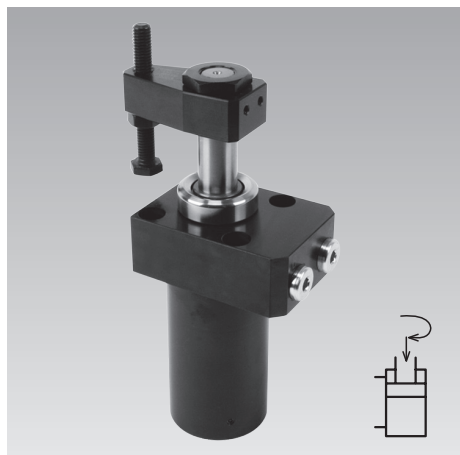

**Swing Clamps with Sturdy Swing Mechanism**

Top flange type, with optional position monitoring, double acting, max. operating pressure 350 bar



**Advantages**

- 5 sizes available
- Compact design partially recessible
- High clamping force at low pressures
- Sturdy swing mechanism
- Insensitive against high flow rates
- Indexing of the clamping arm in a specified position is possible
- Special swing angle easily realisable
- Standard FKM wiper
- Metallic wiper optional
- Throttle valves available as accessory
- Screw counterbores coverable
- position monitoring available in six variants
- Hydraulic and pneumatic ports integrated in the flange
- Mounting position: any

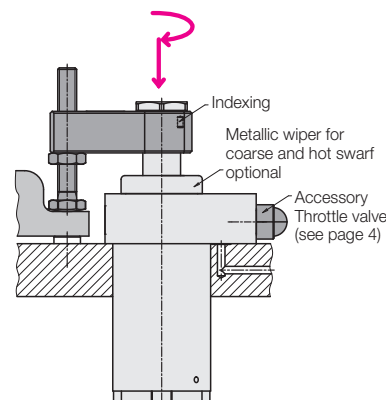

**Application**

Hydraulic swing clamps are used for clamping of workpieces, when it is essential to keep the clamping area free of straps and clamping components for unrestricted workpiece loading and unloading.

Due to the sturdy swing mechanism and the manifold possibilities of position monitoring these swing clamps are particularly suited for

- Automatic manufacturing systems
- Clamping fixtures with workpiece loading via handling systems
- Transfer lines
- Test systems for motors, gears and axes
- Assembly lines
- Special machine tools

**Description**

The hydraulic swing clamp is a pull-type cylinder where a part of the total stroke is used to swing the piston.

The favourable area ratio (piston/piston rod) allows high clamping forces already at relatively low oil pressures.

Due to the sturdy swing mechanism the angle position of the clamping arm remains the same after a slight collision with the workpiece during loading or unloading. Also a collision during the clamping process is not critical.

When using high flow rates the swing speed is limited by installed throttle points.

For connection via drilled channels, adjustable throttle valves can be screwed instead of the screw plugs.

The FKM wiper at the piston rod can be protected against coarse and hot swarf by an optionally available metallic wiper (see page 6).

The different possibilities of the position monitoring are presented at the side.

Important notes see page 6.

**Installation and connecting possibilities**

**Pipe thread**

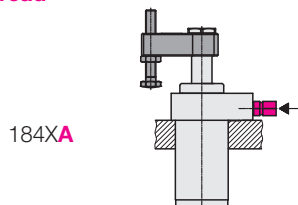

**Drilled channels**

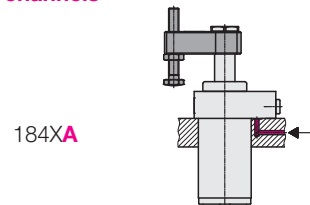

**Pneumatic position monitoring integrated**

**Monitoring of the clamping arm in clamping position (adjustable)**

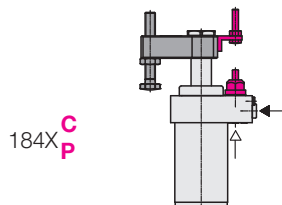

**Position monitoring as accessories**

**Switch rod for external sensors**

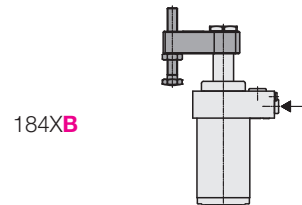

**Monitoring of the piston in unclamping position**

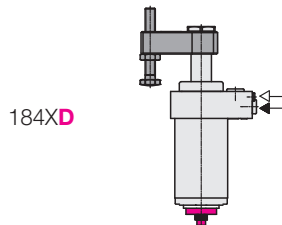

**Pneumatic position monitoring in clamping and unclamping position**

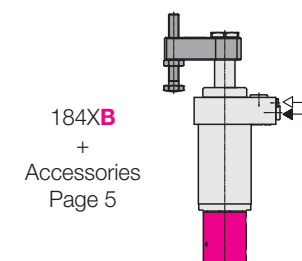

**Both controls combined**

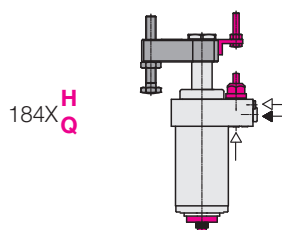

**Electrical position monitoring in clamping and unclamping position**

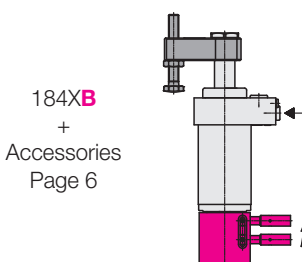

Versions: Code letters **A, B, C, D, H, P, Q**  
 Dimensions • Swing angles

**A** (without monitoring)

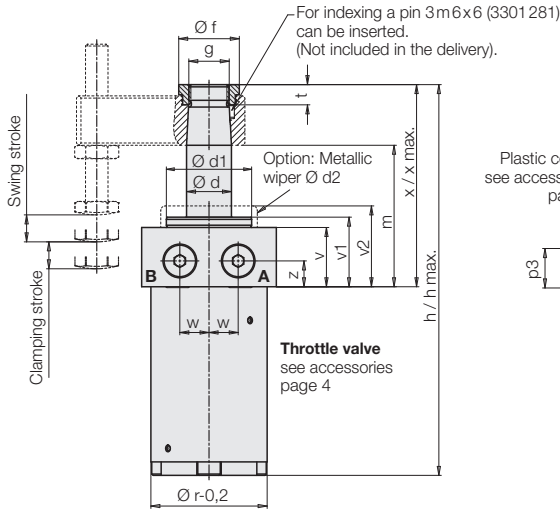

- A** = Clamping
- B** = Unclamping
- E** = Unclamped (pneumatic)
- S** = Clamped (pneumatic)

**B** (with switch rod)

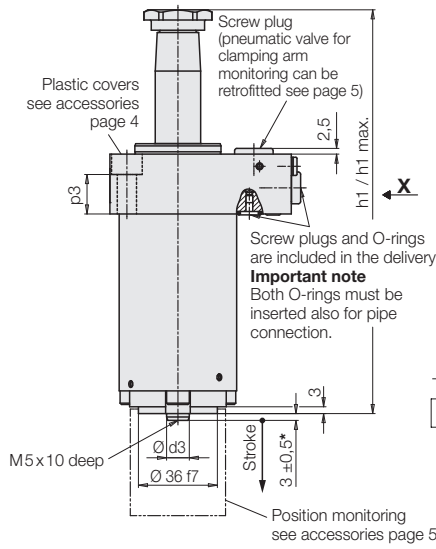

- (Monitoring "Clamped")
- C** Switching area  $2 \div 9$  mm
- P** Switching area  $2 \div 10$  mm

**View X**

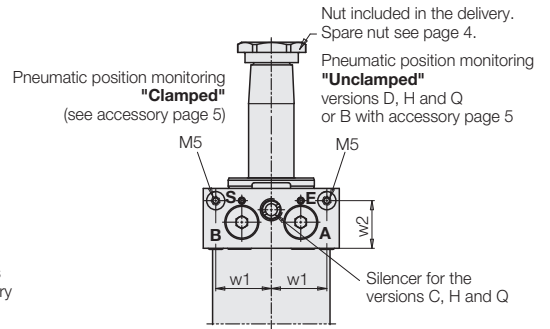

**Connecting scheme**

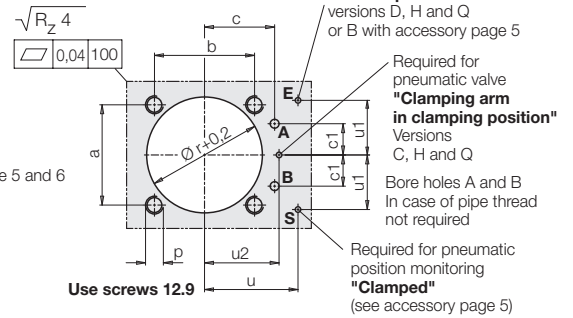

Use screws 12.9  
 Connecting holes:  
 2 x hydraulics (A, B) max. Ø 5  
 Spare-O-ring 8 x 1.5 part no. 3000343  
 3 x pneumatics max. Ø 2.5 (only as required)  
 Spare-O-ring 3.68 x 1.78 part no. 3000334

- H** (Combination C+D)
- Q** (Combination P+D)

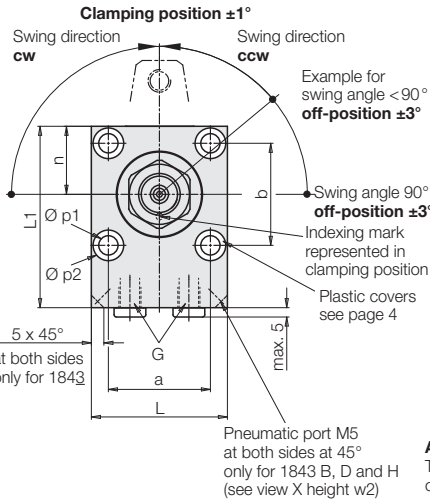

**Attention danger of collision!**

The contact bolt for the actuation of the pneumatic valve must be completely screwed into the angle bracket for start up (see page 4 dimension 3.5 mm)  
 The adjustment is made with clamped workpiece to approx. 5 mm valve stroke.

**D** (Monitoring "Unclamped")

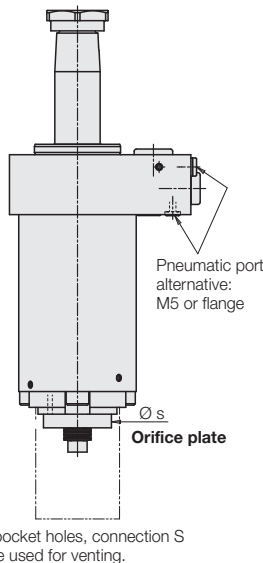

**Important note**

The lower part of the swing clamp must be protected against swarf and dirt for trouble-free functioning of the orifice plate.

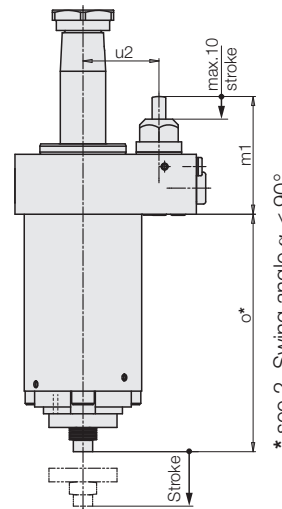

**Pneumatic position monitoring versions C, D, H**

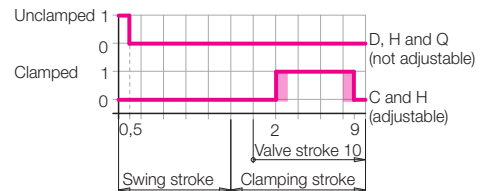

**Versions P, D, Q**

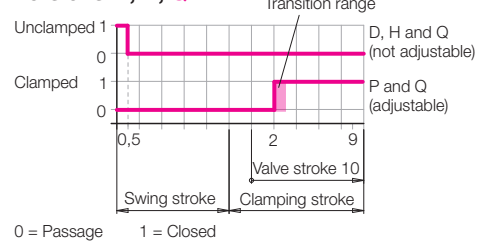

**Swing angle**

**1. Swing angle 90° (standard)**

Part no.	Swing angle
184X X090 RXXD	90° cw
184X X090 LXXD	90° ccw
184X X000 XXD	0°

**2. Swing angle α < 90°**

α = 15° to 75° in gradation of 5°

By insertion of a distance plate the return stroke of the piston is reduced and thus the swing angle is reduced.

Clamping stroke and clamping position remain the same. The swing stroke and the dimensions h, h1, m and x are reduced by y:

$$y = (90^\circ - \alpha^\circ) \cdot k \quad (k \text{ see chart page 3})$$

Example:

Swing clamp	1845A090L30D
Desired swing angle	45° ccw
<b>Part no.</b>	<b>1845A045L30D</b>

Shortening:

$$y = (90^\circ - 45^\circ) \cdot 0.12 \text{ mm}^\circ = 5.4 \text{ mm}$$

**3. Swing angle > 90°**

Available on request!

## Technical data

Max. pulling force (350 bar)	[kN]	7.5	10.5	18.4	27.5	39.1
Effective clamping force	[kN]	see diagram page 3 or calculation of the clamping force on page 4				
Clamping stroke	[mm]	12	12	15	15	15
Swing stroke	[mm]	11	12	15	21	24
Total stroke ± 0.2	[mm]	23	24	30	36	39
Min. operating pressure	[bar]	30	30	30	30	30
Max. flow rate	[cm³/s]	10	14	32	57	87
(see page 4)						
Effective piston area	[cm²]	2.14	3.01	5.27	7.86	11.19
Clamping						
Unclamping						
Oil volume / stroke	[cm³]	4.15	6.15	10.17	15.9	23.75
Oil volume / return stroke	[cm³]	4.9	7.2	15.8	28.3	43.7
Piston Ø	[mm]	23	28	36	45	55
a	[mm]	37	45	54	66	76
b	[mm]	40	45	54	66	76
c	[mm]	28.5	31.5	35	43	56
c1	[mm]	12	14	14	18	20.5
Ø d	[mm]	16	20	25	32	40
Ø d1	[mm]	28	38	45	48	60
Ø d2	[mm]	33	42	54	54.5	75
Ø d3	[mm]	10	10	12	12	12
Ø f	[mm]	27	30	36	40	55
g	[mm]	M14x1.5	M18x1.5	M20x1.5	M28x1.5	M35x1.5
G		G 1/8	G 1/8	G 1/4	G 1/4	G 1/4
h +0.4/-0.3 / h max. <sup>1)</sup>	[mm]	161/162.3	174/175.8	203/204.8	233.5/233.9	254/255.7
h1 +0.4/-0.3 / h1 max. <sup>1)</sup>	[mm]	165/166.3	178/179.8	207/208.8	237.5/237.9	257/258.7
k	[mm/°]	0.091	0.093	0.12	0.152	0.183
L	[mm]	50	62	75	88	100
L1	[mm]	70	81	95	105	120
m +0.4/-0.7 <sup>2)</sup>	[mm]	62.4	63.9	74.9	80.3	84.8
m1	[mm]	52	52	56	56	56
n	[mm]	26.5	31	37	44	50
o	[mm]	98	105	118	136	146
p	[mm]	M6	M8	M10	M12	M12
Ø p1	[mm]	6.6	9	11	13	13
Ø p2 H13	[mm]	11	15	18	20	20
p3	[mm]	18.4	15.4	17.4	15.4	17.4
Ø r	[mm]	45	52	60	76	90
Ø s	[mm]	30	30	33	33	33
t	[mm]	7.5	9	10	10	11
u	[mm]	36.5	42	50	53	62
u1	[mm]	18.5	24.5	28	32	35
u2	[mm]	27	33.5	41.5	44.5	53.5
v	[mm]	26.4	26.4	30.4	30.4	30.4
v1	[mm]	31	31	35	36	36
v2	[mm]	36	36	40	41	41
w	[mm]	12	13	17	20	20.5
w1	[mm]	22.5	24.5	28	32	35
w2	[mm]	22	21	24.5	25	26
x +0.3/-0.2 / x max. <sup>1)</sup>	[mm]	84/85.2	90/91.7	106/107.7	118.5/118.8	128/129.6
z	[mm]	11	11.5	12	12	15
Weight, approx.	[kg]	1.7	2.3	3.9	6	8.9
<b>Part-no.</b>	Swing direction 90° cw	<b>1843 X090 R23DM</b>	<b>1844 X090 R24DM</b>	<b>1845 X090 R30DM</b>	<b>1846 X090 R36DM</b>	<b>1847 X090 R39DM</b>
	Swing direction 90° ccw	<b>1843 X090 L23DM</b>	<b>1844 X090 L24DM</b>	<b>1845 X090 L30DM</b>	<b>1846 X090 L36DM</b>	<b>1847 X090 L39DM</b>
	0 degree	<b>1843 X000 023DM</b>	<b>1844 X000 024DM</b>	<b>1845 X000 030DM</b>	<b>1846 X000 036DM</b>	<b>1847 X000 039DM</b>

Code letter **X** see page 2.

**M** = Option metallic wiper (see also page 6)

<sup>1)</sup> h / h1 / x = upper edge piston      h max. / h1 max. / x max. = upper edge nut

<sup>2)</sup> m = lower edge clamping arm

Effective clamping force with accessory clamping arm as a function of the oil pressure

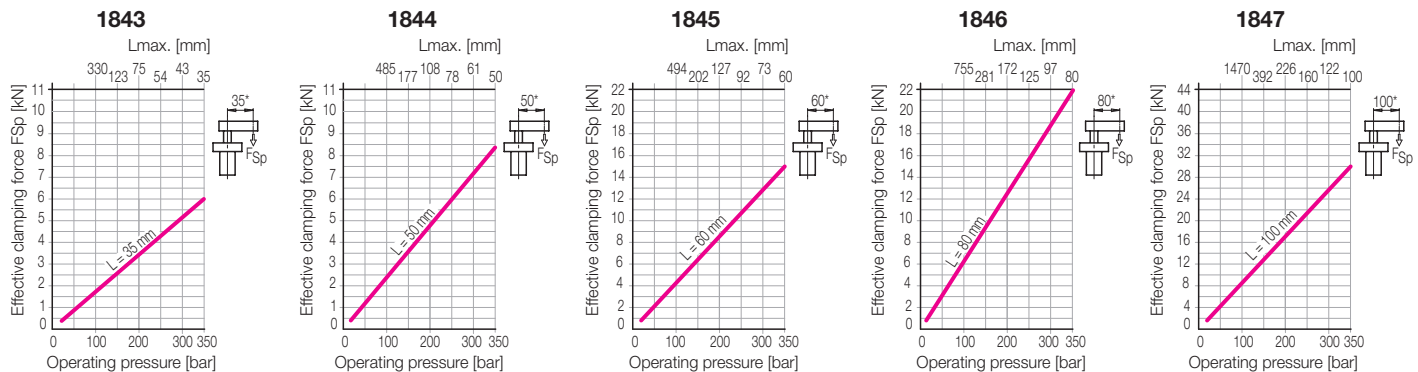

**Clamping arm, max. 350 bar**

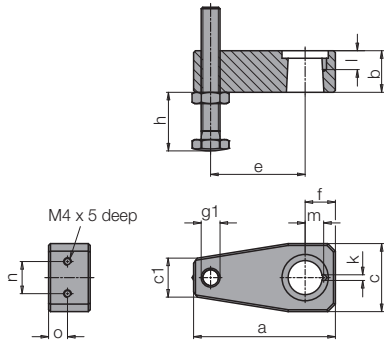

**Clamping arm complete with angle**

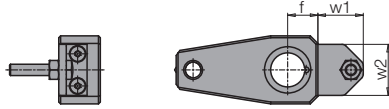
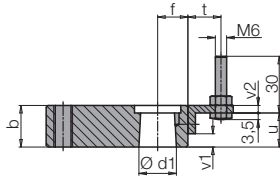

**Special clamping arm**

**1. Connecting dimensions**

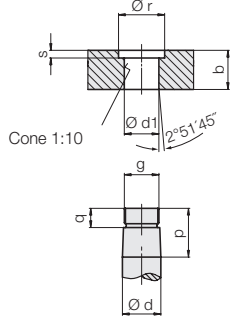

**2. Admissible flow rate Q\***

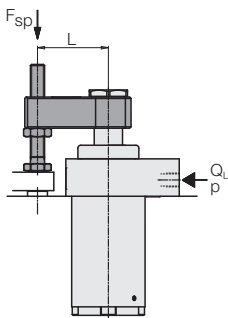

In the chart on page 3, the admissible flow rates for clamping and unclamping with the clamping arms (accessories) are specified.

Longer special clamping arms have a higher torque of inertia. To avoid an overload of the swing mechanism, the flow rate has to be reduced:

**2.1 Moments of inertia are known**

$$Q_L = Q_e \cdot \sqrt{\frac{J_e}{J_L}} \text{ cm}^3/\text{s}$$

Q<sub>L</sub> = Flow rate with special clamping arm

Q<sub>e</sub> = Flow rate as per chart (page 3)

J<sub>e</sub> = Moment of inertia of the clamping arm (accessory) with contact bolt (chart)

J<sub>L</sub> = Moment of inertia special clamping arm determined with the help of the CAD model in the computer

\* Only for vertical mounting position!

Swing clamps		1843	1844	1845	1846	1847
a	[mm]	58	75	93	120	154
b	[mm]	17	22	26	32	38
c	[mm]	28	36	45	60	72
c1	[mm]	14	20	23	28	36
Ø d f7	[mm]	16	20	25	32	40
Ø d1 +0.1/+0.05	[mm]	15.8	19.8	24.8	31.8	39.8
e	[mm]	35	50	60	80	100
f	[mm]	16	16	22	26	34
g	[mm]	M14x1.5	M18x1.5	M20x1.5	M28x1.5	M35x1.5
g1	[mm]	M8	M10	M12	M16	M20
h min/max	[mm]	5/45	6/64	7/70	9/85	12/100
Ø k +0.1	[mm]	3	3	3	3	3
l +0.5	[mm]	9.5	11	11	11.5	12
m ±0.05	[mm]	7.8	9.8	12	15	19
n	[mm]	11	17	20	20	20
o	[mm]	6	10	12	20	20
p	[mm]	22.5	27	32	39	44
q	[mm]	9	10	11	12.7	12.7
Ø r	[mm]	20	24.5	31	34.5	46
s	[mm]	2.5	4	4	4.5	5
t	[mm]	11	17.5	19	19	19
u	[mm]	17	18	21	19	25
v1	[mm]	6	7	8	6	12
v2	[mm]	4	4	5	5	5
w1	[mm]	18	24	26	26	26
w2	[mm]	21	27	30	30	30

**Part no. Clamping arm**

		0354 152	0354 153	0354 154	0354 155	0354 259
- with contact bolt						
Weight, approx.	[kg]	0.19	0.39	0.69	1.43	2.64
Moment of inertia of J <sub>e</sub>	[kgm <sup>2</sup> ]	0.00011	0.00046	0.0011	0.00398	0.01198
- without thread g1						
Weight, approx.	[kg]	0.16	0.34	0.62	1.28	2.34
Moment of inertia of J <sub>e</sub>	[kgm <sup>2</sup> ]	0.00007	0.00033	0.00084	0.00298	0.00896
- complete with angle						
Angle bracket complete		0354 156	0354 157	0354 158	0354 159	0354 175
Plastic cover**		0184 003	0184 004	0184 005	0184 005	0184 005
Metallic wiper		0341 104	0341 107	0341 105	0341 100	0341 101
Spare nut		3527 092	3527 014	3527 099	3527 015	3527 048
Tightening torque	[Nm]	16	30	42	90	160

\*\* Order 4 off per swing clamp

**2.2. Accessory**

**Throttle valve**

Throttle valves are used

- in order to reduce the swing speed of the clamping arm;
- in order to improve the synchronism of several swing clamps.

This application is only possible for manifold-mounting connection through drilled channels.

**Important note**

If throttling is too strong, the back pressure can trigger premature switching of pressure switches and sequence valves.

**Hydraulic symbol**

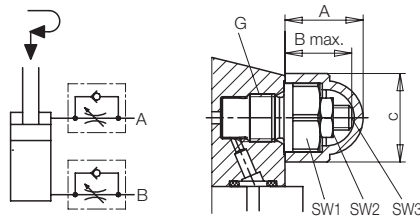

**Swing clamps**

		1843	1846
A	[mm]	16	21
B max.	[mm]	13.5	17.5
C	[mm]	18	23.6
G		G 1/8	G 1/4
SW1	[mm]	14	19
Tightening torque	[Nm]	18	35
SW2	[mm]	8	8
SW3	[mm]	2.5	2.5
Weight	[kg]	0.025	0.036
Part no.		2957 209	2957 210

**Special clamping arm**

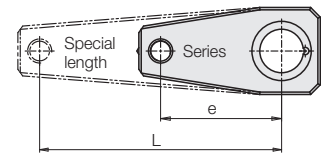

**Clamping force and admissible operating pressure**

Effective clamping force (general)

$$F_{Sp} = \frac{p}{A + (B \cdot L)} \leq F_{adm.} \quad [\text{kN}]$$

Admissible clamping force

$$F_{adm} = \frac{C}{L} \quad [\text{kN}]$$

Admissible operating pressure

$$p_{adm} = \frac{D}{L} + E \leq 350 \quad [\text{bar}]$$

L = special length [mm]      p = pressure [bar]

A, B, C, D, E = constants as per chart

**Constant**

	1843	1844	1845	1846	1847
A	46.64	33.15	18.98	12.72	8.93
B	0.335	0.17	0.073	0.04	0.027
C	210	420	900	1760	3000
D	9795	13926	17078	22386	26805
E	70.26	71.33	65.44	70.36	81.78

**Example:** Swing clamps 1843  
L = 70 mm

**1. Admissible clamping force**

$$F_{adm} = \frac{C}{L} = \frac{210}{70} = 3 \text{ kN}$$

**2. Admissible operating pressure**

$$p_{adm} = \frac{D}{L} + E = \frac{9795}{70} + 70.26 = 210 \text{ bar}$$

# Accessories for 184XB0XX • Pneumatic position monitoring (not adjustable) Pneumatic valve

## Application

A prerequisite for automated processes of work-piece clamping are hydraulic clamping elements whose position can be monitored at any time. The pneumatic position monitorings signal the following conditions by closing two bore holes:

1. Piston extended, clamping arm in off-position.
2. Piston in clamping area, clamping arm in clamping position.

By the pressure increase in the pneumatic line an electro-pneumatic pressure switch or a differential pressure switch can be actuated.

The electrical switching devices are integrated in the electric control so that on the clamping fixture no electricity is required.

## Description

The pneumatic position monitoring consists of the stainless control housing with fit signal sleeve, to be connected to the switch rod of the swing clamp by means of the delivered screw. Four fixing screws are included in our delivery.

## Pneumatic port

### Drilled channels

The swing clamp with the mounted position monitoring is inserted into the location hole and is immediately ready for use with the mounted O-rings.

### Hose connection

Remove the plugs M5 and screw-in connecting nipple M5 (accessory) Sealing to the flange area is made by the two O-rings.

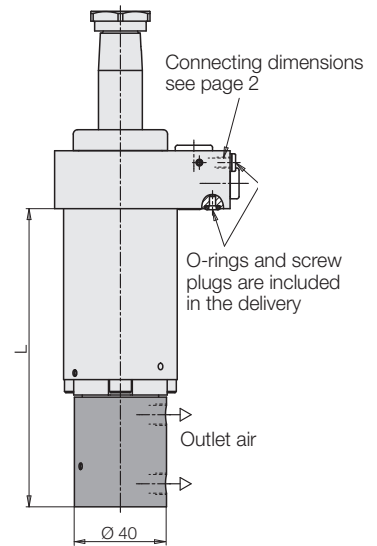
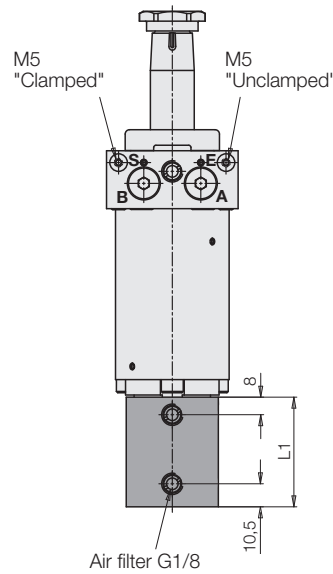

## Technical data

Port	O-ring or thread M5
Nominal diameter [mm]	2
Max. air pressure [bar]	10
Range of operating pressure [bar]	3...5
Differential pressure *) at	
3 bar system pressure [bar]	min. 1.5
5 bar system pressure [bar]	min. 3.5
Air flow rate **) [l/min]	10...20

\*) Required pressure drop if one or several position monitorings are not operated.

\*\*) For measuring the air flow rate appropriate devices are available. Please contact us.

## Function chart

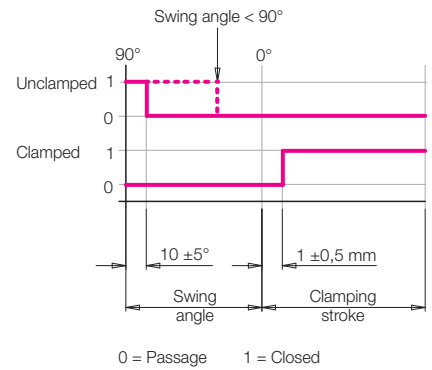

## Monitoring by pneumatic pressure switch

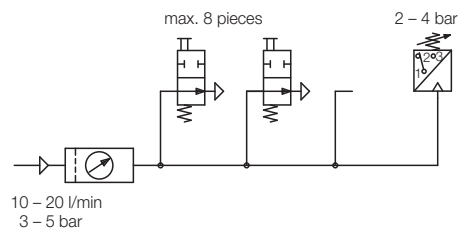

## Part no.

Swing clamps	1843B0XX	1844B0XX	1845B0XX	1846B0XX	1847B0XX
L [mm]	129	136	172	190	200
L1 [mm]	50	50	73	73	73
Swing angle (see page 2)					
0 or 90°	<b>0353913</b>	<b>0353913</b>	<b>0353914</b>	<b>0353916</b>	<b>0353956</b>
15 to 75° = XX	<b>03539130XX</b>	<b>03539130XX</b>	<b>03539140XX</b>	<b>03539160XX</b>	<b>03539560XX</b>
(graduation of 5°)					

## Pneumatic valve

Spare part for versions C, H, P and Q

Switching range 2 - 9 mm  
Switching range 2 - 10 mm  
Max. operating pressure  
Max. tightening torque  
Function charts see page 2.

## Part no.

**0353933**

**0353934**

10 bar

25 Nm

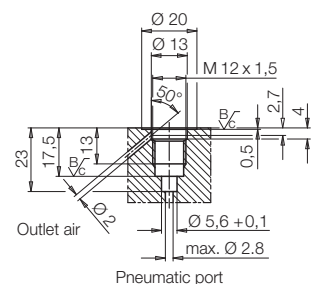
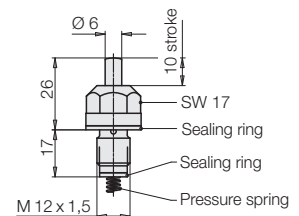



# Accessory for 184XB0XX • Electrical position monitoring (adjustable)

## Important notes • Wiper system • Throttling of flow rate

### Application

Electrical position monitorings signal the following conditions due to damping of two inductive proximity switches:

1. Piston extended, clamping arm in off-position.
2. Piston in clamping area, clamping arm in clamping position.
3. Piston in final position, no workpiece inserted. \*)

\*) If this function is not desired, e.g. in setting mode, the proximity switch can be adjusted so that the switch is still damped at the stroke end (see function chart).

### Description

The electrical position monitoring consists of the housing with two adjustable inductive proximity switches and one switching cam fixed at the switch rod of the swing clamp.

The fixing screws are included in our delivery.

The housing can also be mounted turned by 180°. The radial distance of the proximity switches to the switching cam should be 0.5 mm. It is secured by means of a set screw M4. After untightening of the locking screw M4 the proximity switches can be axially displaced.

### Please note:

Careful design is required. According to the corresponding application conditions, safety measures have to be planned and checked later on. Inductive position monitorings are not suitable for the use in coolant and swarf areas.

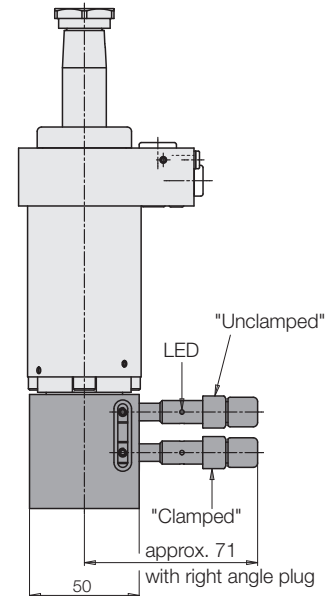
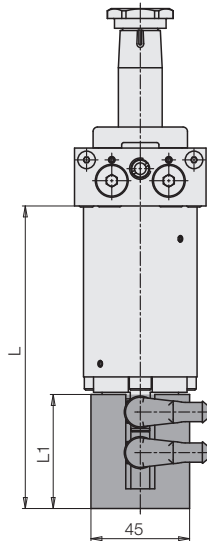

### Technical data

Operating voltage	10...30 VDC
Max. residual ripple	15 %
Max. constant current	200 mA
Switching function	interlock
Output	PNP
Material of housing	stainless steel
Thread	M8x1
Code class	IP 67
Ambient temperature	-25...+70 °C
LED function display	yes
Protected against short circuits	yes
Type of connection	right angle plug
Length of cable	5 m

### Function chart

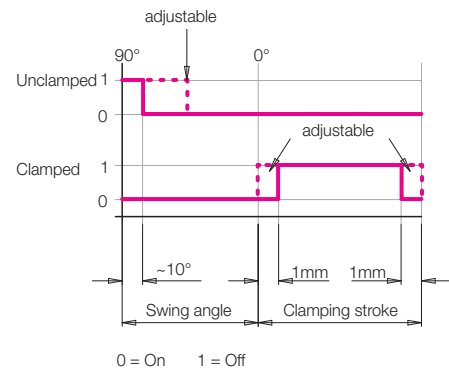

### Part no.

Swing clamps	1843B0XX	1844B0XX	1845B0XX	1846B0XX	1847B0XX
L [mm]	131	138	172	190	200
L1 [mm]	52	52	73	73	73
With switch and plug	<b>0353905</b>	<b>0353905</b>	<b>0353915</b>	<b>0353915</b>	<b>0353915</b>
Without switch and plug	<b>0353906</b>	<b>0353906</b>	<b>0353917</b>	<b>0353917</b>	<b>0353917</b>

### Important notes

Swing clamps must only be used for clamping of workpieces in industrial applications and may only be operated with hydraulic oil. They can generate very high forces. The workpiece, the fixture or the machine must be in the position to compensate these forces.

In the effective area of piston rod and clamping arm, there is the danger of crushing. The manufacturer of the fixture or the machine is obliged to provide effective protection devices.

The swing clamp has no overload protection device. When mounting the clamping arm, the clamping arm or the hexagon socket in the piston have to be backed up for tightening and untightening the fixing nut. During loading and unloading of the fixture and during clamping a collision with the clamping arm has to be avoided.

Remedy: Mount position adaptor.

Operating conditions, tolerances and other data see data sheet A 0.100.

### Wiper system

The standard FKM wiper has a high chemical resistance against most cooling and cutting fluids.

The optional metallic wiper protects the FKM wiper against mechanical damage due to big or hot swarf.

It consists of a radially floating wiping disk and a retaining disk.

The metallic wiper can be delivered already mounted ("M") or as an accessory for retrofitting (see page 4).

### Attention!

The metallic wiper is not suitable for dry machining or minimum quantity lubrication. Also in applications with very little grinding swarf, the standard FKM wiper has a better protection effect.

If there is any danger that small particles stick to the piston rod, the metallic wiper disk can also be replaced by a hard plastic disk.

### Throttling of the flow rate

A flow rate throttling always has to be effected in the supply line to the swing clamp. This avoids a pressure intensification and thereby pressures exceeding 350 bar.

