



Die Changing Carts RWA 1600

with electro-hydraulic lifting platform with die changing table without and with push-pull system, max. load capacity 1,600 kg



Die changing cart RWA 1600

RWA 1600 with push-pull system

Advantages

- Safe, non-destructive die transport of heavy dies
- Time-saving die change
- Integrated die changing table with hydraulic ball bars and push-pull system
- High degree of safety thanks to docking rails and lowerable ball bars
- Prevention of falling die thanks to inserted and secured front and side bars
- Simple and centralized operation with multi-functional drawbar
- Multi-function display on the drawbar
- Robust vehicle technology
- Modular design with standard drive

Application

The die changing cart RWA 1600 is used for the transport and the change of pressing and punching dies as well as injection and casting moulds up to a weight of 1,600 kg.

Description

The die changing cart RWA 1600 is an electrically driven walking and lifting cart, specifically equipped for the safe transport and change of dies.

The electro-hydraulic lifting platform is designed to function as a die changing table with integrated hydraulic ball bars, which facilitate the easy insertion of the dies onto the press table.

Safety devices

Insertable front and side bars on the die changing table secure the die on all sides from falling during transport.

For transport, the centre of gravity of the load must be positioned in the centre of the cart and the lifting columns must be completely lowered.

During transport, the balls in the changing table are always lowered and the die is secured against slipping.

Safety docking station

The docking bars on the changing table (included in delivery) and on the press table (accessory) ensure for precise locking of the die changing cart. Ball inserts can only be lifted after successful docking to the press table. The die weight is supported on the press table.

Versions

Die changing cart RWA 1600 are available with 4, 6 or 8 installed ball bars. A version with a quick-disconnect coupling for external ball or roller bars is available.

Version with push-pull system

The push-pull system allows the user to automatically extend and retract the die at the push of a button without having to be in the danger zone. The dies are moved at a speed of 33 mm/s. Moving at creep speed enables precise positioning of the dies in the press table.

To load and unload the dies using the push-pull system, the dies must be fitted with a die hook (see accessories on page 4).

Power supply

Power is supplied to the electric drive, the lifting platform and the ball bars via an installed 24 V DC battery with 240 Ah.

This battery can be completely charged with the supplied battery charger within 10 hours at 230 V and within 12 hours at 110 V.

Operation

The die changing cart RWA is operated entirely from the multi-functional drawbar.

- Steering by drawbar
- Rotary switch for continuous and sensitive driving (speed control)
- Toggle switch for reduced speed
- Push-button for driving with reduced speed for vertical drawbar position
- Slider control for sensitive lifting and lowering of the lifting platform
- Mushroom push-button for lifting/lowering balls
- Slider control for shifting dies (optional)
- Signal horn and key switch
- Main current safety switch (emergency stop)

Multi-functional display

for display of

- Battery status and operating hours
- Maintenance intervals and error messages

Accessories

see page 4

Optional equipment upon request

see page 5

Die Changing Cart RWA 1600 with Push-Pull System

Technical data • Dimensions

Technical data

Max. die weight F_g	[kg]	1600
Platform size, useable W × D*	[mm]	1150 × 780*
Lifting range	[mm]	250 – 1650
Stroke of the ball bars	[mm]	2
Max. lifting force / bar	[kN]	8.8
Load capacity at the load centre of gravity 400/650 mm	[kg]	1600/600
Ball spacing	[mm]	76
Max. driving speed	[km/h]	5
Running performance		approx. 3 h at full load
Empty weight	[kg]	1200

* Individual platform sizes and ball distances on request

Version	RWA 1600/4	RWA 1600/6	RWA 1600/8
Number of ball bars (each 744 mm long)	4	6	8
Part no.	889131600	889131610	889131620

Die changing cart with quick-disconnect coupling

Part no.	889131601	889131611	889131621
----------	-----------	-----------	-----------

Delivery:

- Changing cart with built-in battery
- Battery charger
- Battery filling system Aquamatic
Filling station with electric pump for fast filling of the batteries with water.
- Lifting platform with 4, 6 or 8 installed ball bars
- Docking bar on the lifting platform
- Removable front and side bars
- Option: Quick-disconnect coupling for external ball bars

Versions as per customer's request

- Roller bars instead off ball bars
- Individual ball and roller distance
- Individual dimensions of lifting platform
- Radio remote control

Please contact us.

Accessories

see page 4

Dimensions

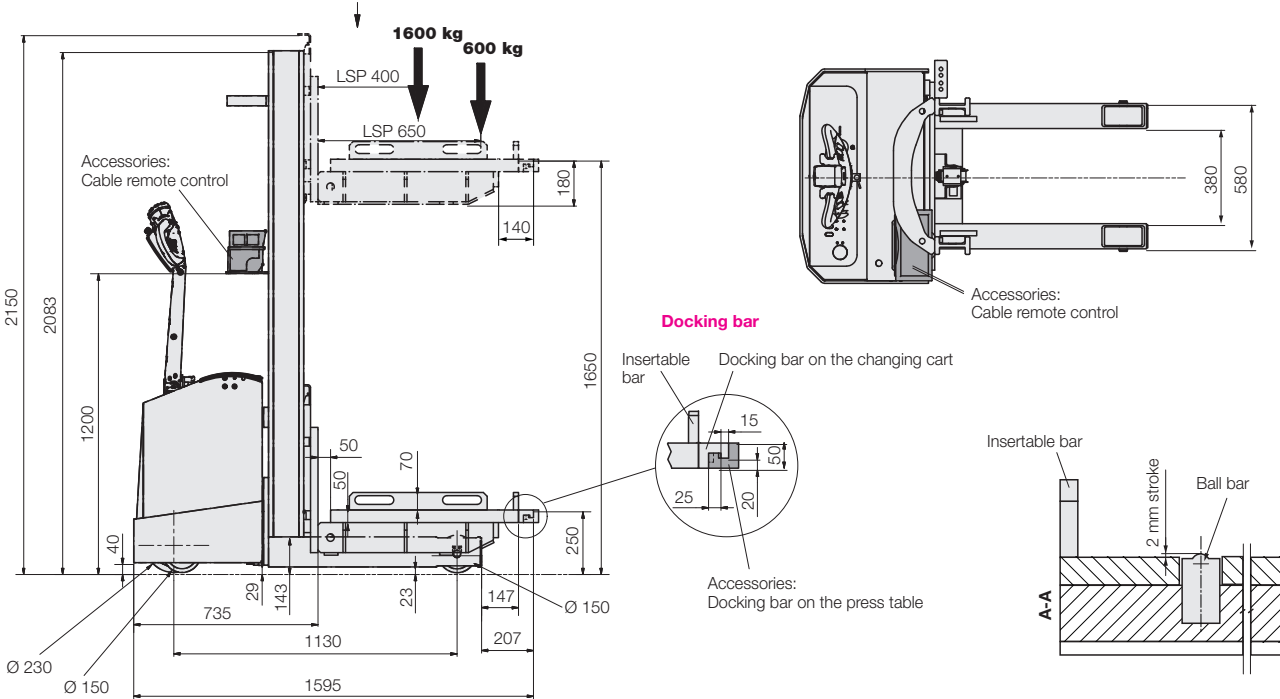

RWA 1600 with 8 hydraulic ball bars
Option: Quick-disconnect coupling for external ball bars

Lifting platform with 6 hydraulic ball bars

Lifting platform with 4 hydraulic ball bars

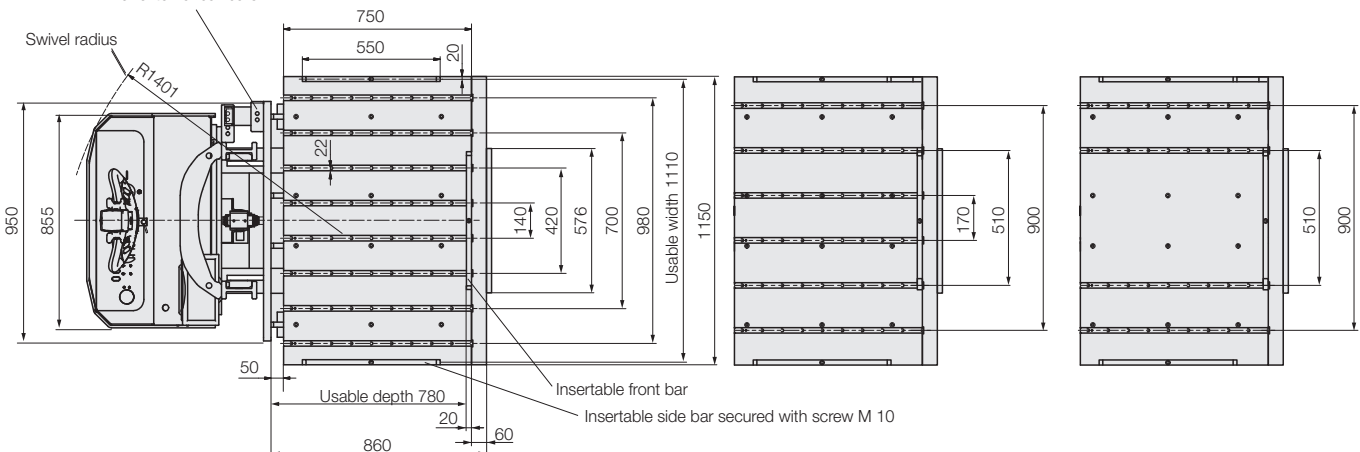

Accessories

Docking bars

To achieve the exact insertion height on the press table, the lifting platform and press table are fitted with screwable docking bars. A docking bar on the changing cart is included in our delivery.

Docking bar

for fixing on the changing cart
L = 1150 mm

Part no. 889130022

Docking bar on other machines/presses

for fixing at the machine/press
L = 576 mm

Part no. 889130023

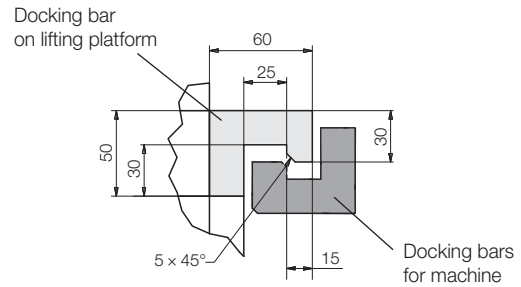

Docking bar light

simplified docking bar for fixing at the machine/press
L = 500 mm

Part no. 789140003

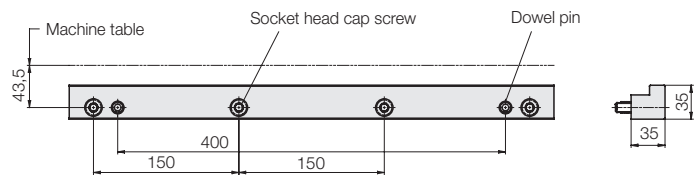

Protection plate for docking bar light

protects the surface of the machine/press from paint damage when docking
L = 500 mm

On request

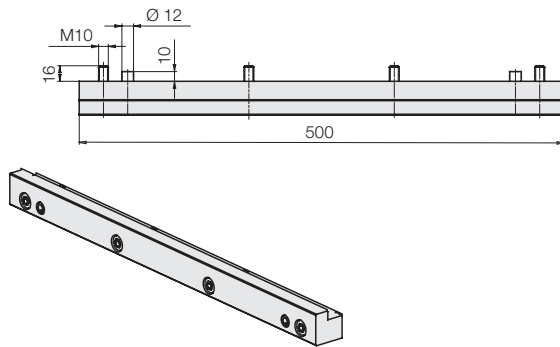

Die hook

for semi-automatic push-pull docking device

To load and unload the dies using the push-pull system, the dies must be fitted with a die hook.

Part no. 718363000

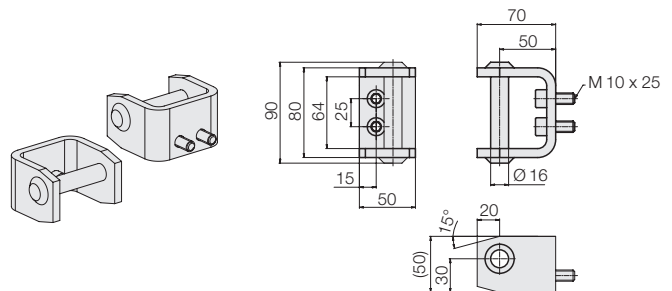

Battery chargers

E 230 G 24/25 B50FP

Charging time: 10 h (at 240 Ah)
Code class: IP 21

Part no. 889130025

E 110/230 G24/22 B50-FPO-WR

Charging time: 12 h (at 240 Ah)
Code class: IP 21

On request



E 110 G24/40 B25 FP-WR

Charging time: 10 h
Code class: IP 21

On request

Optional Equipment upon request

Remote control

The die changing cart can be equipped with an additional cable or radio remote control as an option.

These allow the die changing cart to be operated from a safe distance and provide a better view of the docking point in complex docking situations.

With the functions:

- Lifting/lowering
- Driving forwards/backwards
- Chain forwards/backwards (optional)
- Hydraulic bar lifting
- Emergency stop

Cable remote control

(Mounting position see drawing on page 2)



Radio remote control



Quick-disconnect coupling for external ball or roller bars

The die change cart can optionally be equipped with a quick-disconnect coupling on the hydraulic control circuit (operating pressure 80 bar) as an option for the automatic operation of the hydraulic ball or roller bars in the press table.



Safety stop drop in the docking bar

The docking bar of the die changing cart can be equipped with a belt switch as an option. This switch prevents further lowering once the docking process is complete and serves as an additional safety precaution to prevent damage to the press/rack system/die changing cart.

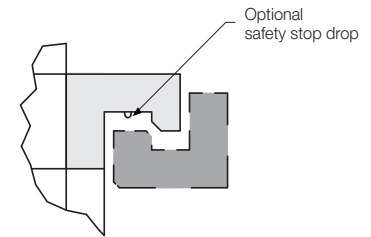

Safety bars for changing tables

Widened lateral tool guide

facilitates the centric mounting of extra-wide dies

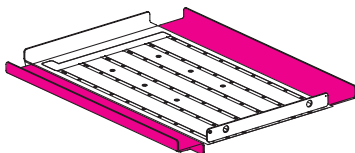

Lateral separator plates

can be lowered for dies that are larger than the platform

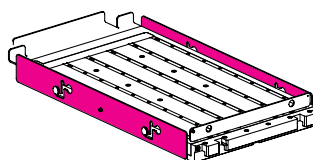

Storage location for insertable safety bars

The die changing cart can be equipped with a storage location on the lifting mast for attaching the insertable safety bars as an option. To transport extra-wide dies, the insertable bars can be removed and attached to the side of the cart.

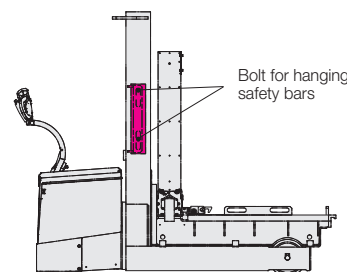

Indicator arrows for position markings

The die changing cart can be equipped with an indicator arrow as an option.

Eight adhesive arrows for position markings made by the customer allow individual die change heights to be marked on the lifting mast, thus reducing the time needed for height adjustment.

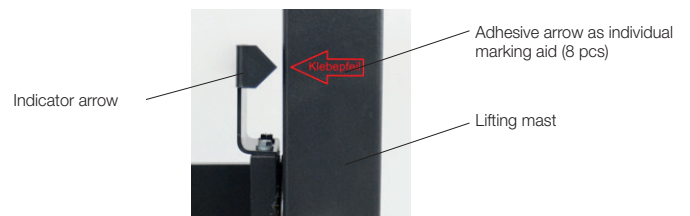

Optional equipment upon request

Welded-on mounting plate for attaching a centring aid

The die changing cart is available with mounting plates as an option. They are welded to the base frame and allow the customer to attach a centring aid to the die changing cart.

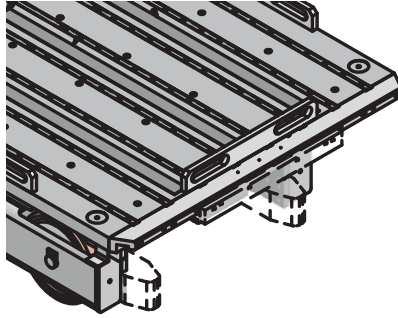

(Fig. similar)

