

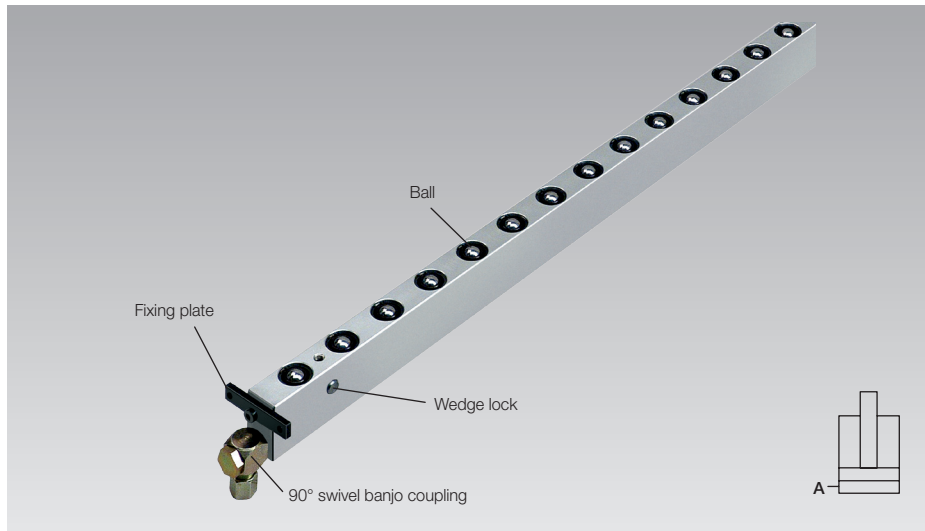

Ball Bars, Hydraulic

with lifting of the individual balls

max. load 70 kN/m, max. operating pressure 100 bar



Advantages

- Easy and safe die change
- Variant program with many selection possibilities
- Hydraulic lifting of each individual ball
- Variable length in a single piece design up to 2900 mm
- Slot depth, ball spacing and bar length configurable for every application
- Low weight (version in aluminium)

Application

- In T-slots and rectangular slots of the press bed for easy die change without any problems
- Die change streamlining

Delivery

- Ball bar
- Fixing plate
- 90° swivel banjo coupling

Description

Ball bar with hydraulic lifting of the individual balls for medium loads and flexible horizontal movement of the dies.

Oil pressure is applied to lift each ball insert individually. The die positioned on the ball bars is not in contact with the table top and can be easily moved and positioned.

T-slot tolerances as per DIN 650

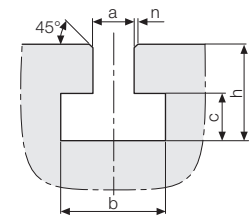

a	b	c	h min.	h max.	n max.
18 H12	30 ⁺²	12 ⁺²	30	36	1.6
22 H12	37 ⁺³	16 ⁺²	38	45	1.6
28 H12	46 ⁺⁴	20 ⁺²	48	56	1.6
36 H12	56 ⁺⁴	25 ⁺³	61	71	2.5

Dimensions in mm

h_{min.} = minimum dimension as per DIN 650

Technical data

Max. operating pressure [bar]	100
Max. load [kN/m]	70
Ball spacing	flexible
Material of the bar	aluminium or steel
Max. temperature [°C]	with aluminium bars: 100 with steel bars: 250
Fixing of the bar	fixing plate or wedge lock
Max. bar length* [mm]	variable* up to 2900

* The minimum bar lengths depends on the ball spacing G with at least 3 balls (see page 2)

Technical data • Dimensions

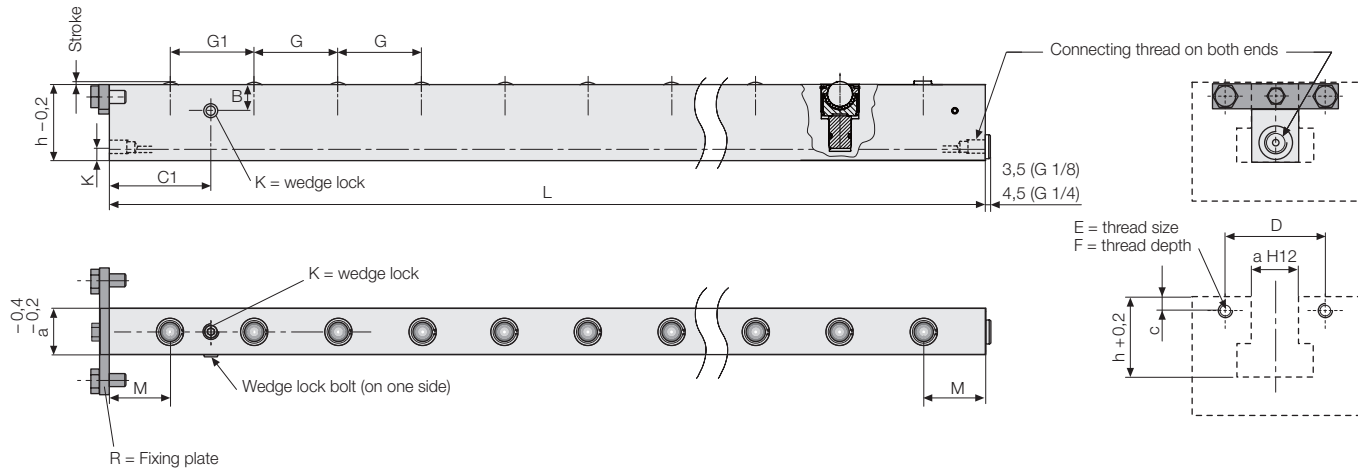

Technical data

Slot width (a)	[mm]	18	22	28	36	13/16"	11/16"
Slot depth min. (h)	[mm]	29.5	37	42	53	29.4	37.4
Slot depth standard (h)	[mm]	30	38	48	61	29.4	38.9
Slot depth max.** (h)	[mm]	45	55	60	75	40	58
Ball spacing G min.	[mm]	20	23	28	34	20	23
Ball spacing G1 min.	[mm]	26	32	37	43	26	32
Ball spacing G/G1 standard	[mm]	30	40	45	50	30	40
Ball spacing G/G1 max.	[mm]	60	80	90	100	60	80
L min.	[mm]	*)	*)	*)	*)	*)	*)
L max.	[mm]	2900	2900	2900	2900	2900	2900
Stroke	[mm]	1	2	2	2	1	2
Longer stroke	[mm]	-	-	3	3	-	-
Load/ball	[kN]	0.79	1.1	1.5	2.5	0.79	1.1
Connecting thread		G 1/8	G 1/8	G 1/4	G 1/4	G 1/8	G 1/4
Oil volume/ball insert	[cm ³]	0.08	0.23	0.31	0.51	0.08	0.23
B	[mm]	12	16	16	16	12	16
C	[mm]	5	7	9	10	5	7
C1	[mm]	35	46	51	56.5	35	46
D	[mm]	36	40	50	55	36	40
E	[mm]	M5	M5	M6	M6	M5	M5
F	[mm]	8	8	12	12	8	8
K	[mm]	8	8.5	11	11	8	11
M	[mm]	22.5	30	32.5	35	22.5	30

*) L min. depends on the ball spacing G with at least 3 balls

**) only with steel bars

Fixing plate and 90°elbow coupling are included in the delivery.

Product configurator

For the selection and configuration of roller and ball bars, a product configurator is available on our website.

After entering the parameters, the configurator determines the desired roller or ball bars with all technical data and the identification number of the characteristics which are identical with the order number. In addition, a drawing with all dimensions will be provided.

Link to the configurator:

www.roemheld-gruppe.de/productconfigurator/?lang=en



Code for part numbers Variant program

Ball bars with hydraulic lifting are individually configured and manufactured depending on the application.

Within the limits specified in the measurement chart, the following parameters can be selected based on a code for part numbers:

bar material, slot width, bar lengths, fixation, slot depth, ball spacing and ball orientation.

• **Stroke**

The ball bar is equipped with standard stroke (1 or 2 mm). For slot width 28 and 36, alternatively a larger stroke of 3 mm is available.

• **Bar material/operating temperature**

Aluminium or steel can be selected as bar material. For operating temperatures > 100 °C, a steel version is required. Depending on the temperature range, the admissible carrying force of the ball bars is reduced:

- up to 100 °C: 100 % of the carrying force
- > 100 – 150 °C: 95 % of the carrying force
- > 150 – 200 °C: 70 % of the carrying force
- > 200 – 250 °C: 60 % of the carrying force

e.g. steel up to 200 °C with 70 % of the carrying force

• **Slot width (a)**

Selection from the table on page 2

e.g. a = 28 mm

• **Bar lengths (L)**

Depending on the ball spacing (G) and the parameter (M) results the possible bar length. Indicate the desired length (e.g. bed length) for your ball bar. Please note that a ball bar must be equipped with at least 3 balls.

e.g. L = 1445 mm

• **Fixation**

- K = wedge lock
- R = fixing plate

e.g. fixing plate = R

• **Slot depth (h)**

If the slots in your application are lower than the default value, specify the corresponding dimension (up to h min.)

For slots which are deeper than the default value, spacer bars can be inserted. For steel versions, specify the corresponding dimension (up to h max.).

e.g. h = 43 mm

• **Ball spacing (G) or load of the bar**

By changing the spacing of the balls, the load of the ball bar can be varied. Please note that the load is indicated for the full length of the bar. Therefore, both the load and the ball spacing must be selected to suit the die weight and the die supporting length.

Please indicate the desired ball spacing or load of the ball bar, or the maximum die weight and the die dimensions.

Note for the calculation of the bar length

The spacing of the first two balls G1 is limited by the position of the wedge lock.

The following applies: G=G1, however when selecting G < G1 min the spacing G1 will not be reduced below the minimum value.

e.g. G = 60 mm

or **load per bar = 36 kN**

or **number of balls = 24**

or **die weight and exterior dimensions**

Code for part numbers

Variant program

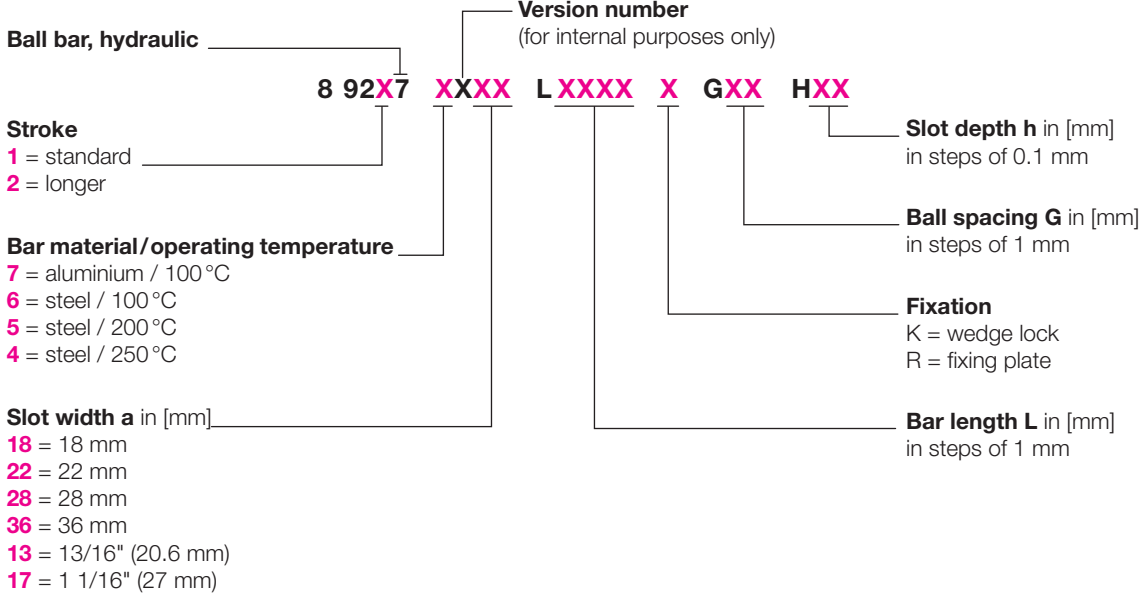

Page 4 shows an example of the part numbers for aluminium bars with standard ball spacing “G” and standard slot depth “h”.

Example of ordering

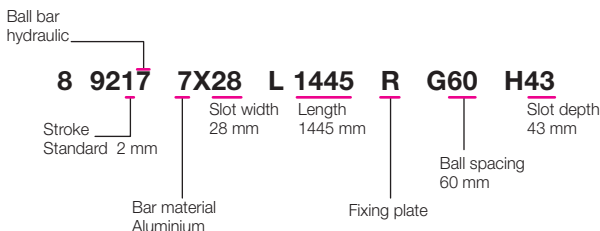

**Extract from the possible variants for ball bars
with standard ball spacing "G", standard slot depth "h" and bar material aluminium**

for slot width a = 18 mm

Length (L) [mm]	Load [kN]	Number of balls	Part no.
105	2.3	3	892177118 L 105 R
135	3.1	4	892177118 L 135 R
165	3.9	5	892177118 L 165 R
195	4.7	6	892177118 L 195 R
255	6.3	8	892177118 L 255 R
315	7.9	10	892177118 L 315 R
375	9.4	12	892177118 L 375 R
435	11.0	14	892177118 L 435 R
495	12.6	16	892177118 L 495 R
555	14.2	18	892177118 L 555 R
615	15.8	20	892177118 L 615 R
675	17.3	22	892177118 L 675 R
735	18.9	24	892177118 L 735 R
795	20.5	26	892177118 L 795 R
855	22.1	28	892177118 L 855 R
915	23.7	30	892177118 L 915 R
other lengths are possible up to max. 2895			
2895	75.8	96	892177118 L 2895 R

for slot width a = 22 mm

Length (L) [mm]	Load [kN]	Number of balls	Part no.
140	3.3	3	892177122 L 140 R
180	4.4	4	892177122 L 180 R
220	5.5	5	892177122 L 220 R
260	6.6	6	892177122 L 260 R
340	8.8	8	892177122 L 340 R
420	11.0	10	892177122 L 420 R
500	13.2	12	892177122 L 500 R
580	15.4	14	892177122 L 580 R
660	17.6	16	892177122 L 660 R
740	19.8	18	892177122 L 740 R
780	20.9	19	892177122 L 780 R
820	22.0	20	892177122 L 820 R
900	24.2	22	892177122 L 900 R
980	26.4	24	892177122 L 980 R
1060	28.6	26	892177122 L 1060 R
1140	30.8	28	892177122 L 1140 R
1220	33.0	30	892177122 L 1220 R
1300	35.2	32	892177122 L 1300 R
other lengths are possible up to max. 2900			
2900	79.2	72	892177122 L 2940 R

for slot width a = 28 mm

Length (L) [mm]	Load [kN]	Number of balls	Part no.
155	4.5	3	892177128 L 155 R
200	6.0	4	892177128 L 200 R
245	7.5	5	892177128 L 245 R
290	9.0	6	892177128 L 290 R
380	12.0	8	892177128 L 380 R
470	15.0	10	892177128 L 470 R
560	18.0	12	892177128 L 560 R
650	21.0	14	892177128 L 650 R
695	22.5	15	892177128 L 695 R
740	24.0	16	892177128 L 740 R
830	27.0	18	892177128 L 830 R
920	30.0	20	892177128 L 920 R
965	31.5	21	892177128 L 965 R
1010	33.0	22	892177128 L 1010 R
1100	36.0	24	892177128 L 1100 R
1190	39.0	26	892177128 L 1190 R
1280	42.0	28	892177128 L 1280 R
other lengths are possible up to max. 2900			
2900	96	64	892177128 L 2945 R

for slot width a = 36 mm

Length (L) [mm]	Load [kN]	Number of balls	Part no.
170	7.5	3	892177136 L 170 R
220	10.0	4	892177136 L 220 R
270	12.5	5	892177136 L 270 R
320	15.0	6	892177136 L 320 R
420	20.0	8	892177136 L 420 R
520	25.0	10	892177136 L 520 R
620	30.0	12	892177136 L 620 R
720	35.0	14	892177136 L 720 R
820	40.0	16	892177136 L 820 R
920	45.0	18	892177136 L 920 R
1020	50.0	20	892177136 L 1020 R
1120	55.0	22	892177136 L 1120 R
1220	60.0	24	892177136 L 1220 R
1320	65.0	26	892177136 L 1320 R
other lengths are possible up to max. 2870			
2870	142.5	57	892177136 L 2920 R

for slot width a = 13/16"

Length (L) [mm]	Load [kN]	Number of balls	Part no.
105	2.3	3	892177113 L 105 R
135	3.1	4	892177113 L 135 R
165	3.9	5	892177113 L 165 R
195	4.7	6	892177113 L 195 R
255	6.3	8	892177113 L 255 R
315	7.9	10	892177113 L 315 R
375	9.4	12	892177113 L 375 R
435	11.0	14	892177113 L 435 R
495	12.6	16	892177113 L 495 R
555	14.2	18	892177113 L 555 R
615	15.8	20	892177113 L 615 R
675	17.3	22	892177113 L 675 R
735	18.9	24	892177113 L 735 R
795	20.5	26	892177113 L 795 R
855	22.1	28	892177113 L 855 R
915	23.7	30	892177113 L 915 R
other lengths are possible up to max. 2895			
2895	75.8	96	892177113 L 2925 R

for slot width a = 1 1/16"

Length (L) [mm]	Load [kN]	Number of balls	Part no.
140	3.3	3	892177117 L 140 R
180	4.4	4	892177117 L 180 R
220	5.5	5	892177117 L 220 R
260	6.6	6	892177117 L 260 R
340	8.8	8	892177117 L 340 R
420	11.0	10	892177117 L 420 R
500	13.2	12	892177117 L 500 R
580	15.4	14	892177117 L 580 R
660	17.6	16	892177117 L 660 R
740	19.8	18	892177117 L 740 R
820	22.0	20	892177117 L 820 R
900	24.2	22	892177117 L 900 R
980	26.4	24	892177117 L 980 R
1060	28.6	26	892177117 L 1060 R
1140	30.8	28	892177117 L 1140 R
1220	33.0	30	892177117 L 1220 R
1300	35.2	32	892177117 L 1300 R
other lengths are possible up to max. 2900			
2900	79.2	72	892177117 L 2940 R

Fixing plate = R
Wedge lock = K